

MIT Utilities

Design Standards

DIVISION 33 — Utilities

Issued 2022

Table of Contents

1. MISSION STATEMENT	4
2. COMMON UTILITIES DESIGN ISSUES	4
2.1 DEMOLITION PLAN	4
2.2 COORDINATION	4
2.3 GENERAL DESIGN REQUIREMENTS	5
2.4 QUALITY CONTROL	5
2.5 CODE COMPLIANCE.....	6
2.6 COLOR CODING FOR VALVE BOX COVERS	6
2.7 MAINTENANCE ACCESS.....	7
2.8 CORROSION PROTECTION	7
2.9 METERING	9
3. MISCELLANEOUS UTILITIES	12
3.1 COMPRESSED AIR	12
3.2 FIRE DETECTION AND ALARM.....	13
3.3 TEL/DATA.....	13
3.4 EMERGENCY POWER	13
3.5 LAB WASTE	13
3.6 NOX EMISSIONS	13
4. 331000 - WATER UTILITIES.....	13
4.1 DOMESTIC WATER INFORMATION.....	14
4.2 DOMESTIC WATER DESIGN ISSUES.....	14
4.3 DOMESTIC WATER METERING	15
4.5 FIRE PROTECTION DESIGN ISSUES	17
4.6 QUALITY ASSURANCE	18
4.7 PRODUCTS	18
4.8 INSTALLATION	19
5. 333000 - SANITARY SEWERAGE UTILITIES	19
5.1 SANITARY SEWER INFORMATION	19
5.2 SANITARY SEWER DESIGN ISSUES.....	19
5.3 SANITARY SEWER QUALITY ASSURANCE	21
5.4 SANITARY SEWER PRODUCTS	21

5.4.1	UNDERGROUND STRUCTURES AND MANHOLES	21
5.4.2	PIPING	22
5.5	SANITARY SEWER INSTALLATION	24
6.	334000 - STORM DRAINAGE UTILITIES.....	24
6.1	STORM DRAINAGE INFORMATION	24
6.2	STORM DRAINAGE DESIGN ISSUES	25
6.3	STORM DRAINAGE QUALITY ASSURANCE.....	26
6.4	STORM DRAINAGE PRODUCTS.....	26
6.4.1	UNDERGROUND STRUCTURES WITH SOLID COVERS	26
6.4.2	UNDERGROUND STRUCTURES AND CATCHBASINS.....	27
6.4.3	PIPE, JOINTS, AND BRICK.....	28
6.5	STORM DRAINAGE INSTALLATION	29
7.	337000 - ELECTRICAL UTILITIES	29
7.1	ELECTRICAL INFORMATION	29
7.2	UTILITIES ELECTRICAL DESIGN ISSUES.....	29
7.3	QUALITY ASSURANCE	31
7.4	PRODUCTS	31
7.5	INSTALLATION	32
8.	337119 - DUCTBANKS	32
8.1	DUCTBANK INFORMATION.....	32
8.2	DUCTBANK DESIGN ISSUES	32
8.3	QUALITY ASSURANCE	36
8.4	INSTALLATION	36
9.	335000 – STEAM AND CONDENSATE UTILITIES	37
9.1	STEAM AND CONDENSATE INFORMATION	37
9.2	STEAM AND CONDENSATE DESIGN ISSUES	37
9.3	STEAM AND CONDENSATE QUALITY ASSURANCE.....	38
9.4	STEAM AND CONDENSATE PRODUCTS.....	38
9.5	STEAM AND CONDENSATE METERING.....	39
10.	336000 – MEDIUM TEMPERATURE WATER UTILITIES.....	41
10.1	MEDIUM TEMPERATURE WATER INFORMATION.....	41
10.2	MEDIUM TEMPERATURE WATER DESIGN ISSUES	41
10.3	MEDIUM TEMPERATURE HOT WATER QUALITY ASSURANCE.....	42
11.	338000 – CHILLED WATER UTILITIES	44
11.1	CHILLED WATER INFORMATION.....	45

11.2	CHILLED WATER DESIGN ISSUES	45
11.3	CHILLED WATER QUALITY ASSURANCE	46
11.4	CHILLED WATER METERING	46
12.	339000 – NATURAL GAS UTILITIES	48
12.1	NATURAL GAS INFORMATION	48
12.2	NATURAL GAS DESIGN ISSUES.....	48
12.3	NATURAL GAS QUALITY ASSURANCE	49
 APPENDIX A - SANITARY SEWER OVERVIEW		
 APPENDIX B - STORMWATER OVERVIEW		
 APPENDIX C - BUILDING ENTRANCES		
 APPENDIX D - UTILITIES DETAILS		

1. MISSION STATEMENT

The design of utility systems and the equipment specified for utilities should allow for maintenance with the priority on public safety. The equipment life should exceed 40 years with consideration of longer life evaluated against initial capital cost where equipment has not been standardized.

Products are standardized for maintainability and overall system reliability. New products may be considered for added longevity and future availability.

MIT promotes creative solutions to design challenges balanced by the constant emphasis on reducing requirements for maintenance of equipment while increasing energy savings.

2. COMMON UTILITIES DESIGN ISSUES

2.1 Demolition Plan

Prepare and implement a demolition plan to safeguard the health and safety of workers at the job site and the general public. Conduct a survey to identify all potential hazards and communicate such matters to MIT's Utility Group and Environment, Health and Safety Department. Comply with OSHA standard 29 CFR 1926.850(a) for demolition.

2.2 Coordination

Coordinate design work with existing services and the work of other disciplines. Locate all utility services and determine the necessity to maintain them during renovation work. Utilize test pit data and select test pit locations to identify potential interference locations with existing systems.

Coordinate the Construction Documents to ensure that new work does not conflict with ducts, structure, lighting systems, architectural finishes and other work. Verify ceiling heights and pipe locations including low points of pitched piping.

In general, the Utility is considered to begin at the first isolation valve inside the building and continues to the City or Eversource connection in the public way.

When conducting subsurface utility drilling for any MIT project, all contractors shall use these steps as a guideline:

1. Identify boring locations based on Subsurface Utility Engineering plans.
2. All parties (Civil Engineer, Geotechnical Engineer, MIT) to review the drilling locations for proximity to surveyed utilities. (Drilling shall not commence until all parties have confirmed their review of the plans and acceptance of the locations.)

3. Mark locations in field and notify DigSafe. (Geotechnical engineer will take a photo of the marked location(s) and share with the team prior to mobilizing the drill rig.)
4. After the Site is marked by Dig Safe and it's member utilities; Geotechnical engineer will review the DigSafe surface markings in the field for consistency.
5. If DigSafe identifies known utilities at the drill location then select new location based on the DigSafe markings. (New locations that are offset in the field based on utility markings OR based on refusal during pre-excavations) will be reviewed in accordance with Steps 1 through 4 above. Unless the boring offset is outside of the Dig Safe area, Dig Safe will not be contacted again.
6. Pre-clear the drilling area with vacuum excavation to a depth of 10 feet to confirm there are no utilities present.
7. Proceed with drilling after confirming with all parties (Civil Engineer, Geotechnical Engineer, MIT) that there are no known utilities present.

2.3 General Design Requirements

Plan view drawings are to be at a scale of 1" = 20'.

Plan views, including existing utilities, are to be provided.

Profile drawings, including existing drawings, shall be provided.

Cross section drawings shall be provided at key locations for clarity.

Technical specifications for all aspects of the construction shall be provided.

Any utilities subject to traffic (including walkways with service vehicle traffic) shall be designed to H20 loading capability.

Any utilities piping passing under a railroad track shall be installed in a steel casing. Work within the railroad right-of-way shall be subject to the control and requirements of Massachusetts Department of Transportation (Mass DOT).

Specifications should include selection and design of supports, anchors, guides and thrust blocks. Where appropriate review options for expansion of piping system (i.e. expansion loops, expansion joints, configured Z- bends). Design for underground utilities should take into consideration the soil and environment associated with the Cambridge area namely high water tables, and pH levels.

2.4 Quality Control

Develop and review field quality control process for contractor and third-party testing, cleaning, and initial chemical treatment for appropriate systems.

Specify products of acceptable manufacturers which have been in satisfactory use in similar service for three years. Use experienced installers. Instruct contractors to deliver handle, and store materials in accordance with manufacturer's instructions.

2.5 Code Compliance

Assure compliance with all governing codes and regulations, including all local building codes.

All MIT projects must comply with the Land Disturbance Regulations adopted by the City of Cambridge Commissioner of Public Works. The Land Disturbance Regulations are intended to bring Cambridge into compliance with the Federal Clean Water Act in 40 CFR 122.34.

Excavated soil is likely to be considered contaminated under Massachusetts Contingency Plan (MCP).

2.6 Color Coding for Valve Box Covers

Valve box covers should be color coded on the underside of the cover to indicate the system they service. Covers should be marked according to the following chart:

UTILITY SERVICE	COLOR MARKING
Chilled Water	Purple
Domestic Water	Green
Medium Temperature Hot Water	White
Fire Protection	Red
Natural Gas	Yellow
Compressed Air	Blue
Steam	Gray

The color markings indicated in this chart attempt to emulate the ANSI/ASME A13.1 guidelines.

Additionally valve box covers should be labeled to identify the type of service on the cover themselves. Supply and return lines should end with an “S” and “R” respectively. See Detail M4 for example. MIT FP valve covers can be supplied by MIT.

UTILITY SERVICE	VALVE COVER SHAPE	DESIGNATION
Chilled Water	Round	CHWS/CHWR
Domestic Water	Round	DW
Medium Temperature Hot Water	Round	MTHWS/MTHWR
Fire Protection (MIT owned)	Square	MIT FP
Natural Gas	Square	NG
Steam	Round	STM

2.7 Maintenance Access

Provide manholes and piping systems with space for adequate venting, draining, and maintenance. Valves and instruments must be located for ease of operation, accessibility, and readability. Provide for operation of isolation valves and bypass valves from street level using reach rods.

2.8 Corrosion Protection

Design should provide cathodic and corrosion protection. Corrosion protection should be provided both for the utilities themselves and for any supporting structures including concrete used in design for ductbanks and manholes and trench boxes.

Provide a Cathodic Protection System for all direct buried steel piping systems and pipe with steel outer casings including chilled water lines, steel conduit for steam and condensate lines, condenser water lines, and steel natural gas lines. Steel lines with adequate outer protection (covering) may not require cathodic protection at the direction of the MIT Program Manager. Provide complete cathodic isolation kits for pipe flanges to meet MIT's pressure service standards.

Provide complete isolation kits for pipe flanges to provide cathodic isolation.

Service Standards: Provide isolation kits appropriate for M.I.T. pressure standards:

- | | |
|-----------------------------|---------|
| 1. Steam Distribution Mains | 300 lb. |
| 2. Condensate | 150 lb. |
| 3. Chilled Water | 150 lb. |
| 4. Condenser Water | 150 lb. |

Isolation Kit Materials: Specify as follows; substitutions are not acceptable. One complete kit consists of the following:

1. Bolt Sleeves: 1 per bolt, silicone rubber, fiberglass composite.
2. Washers Type 1: 2 per bolt, Klingerite.
3. Washers Type 2: 2 per bolt, cadmium plated steel.
4. Gaskets: 1 per flange, Klingerite.

Cathodic Corrosion Protection System for Underground Piping and Pipe Casings.

Provide sacrificial anode type cathodic corrosion protection systems for all direct burial steel pipes with steel outer casings including, without limitation, chilled water lines, steel conduit for steam and condensate lines, and condenser water lines.

Designer Qualifications: The designer of the cathodic corrosion protection system must be a recognized firm specializing in this work and must assume responsibility for the performance and adequacy of the system. Shop drawings shall be submitted, stamped by a professional engineer in responsible charge of the system design.

Complete System Required: Provide a complete system including, without limitation, anodes, wiring, test stations, installation instructions, and all other components and accessories needed for a fully functional system.

System Design Parameters: Base design on 7 percent of pipe surface considered bare and not less than 2 milliAmps of current per square foot of bare surface. Use magnesium anodes and design for 20-year life span.

Test Stations: Provide test stations along the pipe not over 500 feet apart. Terminate test leads at ground surface in cast iron housings encased in concrete or, if structures are nearby, house test leads in electrical conduit and terminate in waterproof junction boxes attached to the structure. Provide at least 18" of slack lead in the terminating box.

Below Grade Conditions: Prior to system installation, make an earth resistivity survey along the line of buried piping, taking at least five soil samples from representative locations. For each sample, determine the chemical analysis, electrical resistivity, pH, percentage of water-soluble salts, chloride content, and sulfate content. Employ specialists for this testing and provide detailed written reports with conclusions.

Electrical Isolation: Electrically isolate cathodic protected piping from other buried structures and from connected building piping systems with Cathodic Protection System - Isolation Kits as described in this Guideline.

Connections to Piping: Make underground wiring connections by the cadwelding process.

Preconstruction Submittals: Provide complete schematic drawings of the entire proposed system and obtain approval from M.I.T. Project Manager prior to continuing work. Accurately show the layout of the system, the number of anodes, the location and number of test stations, details of test stations and wiring, installation details including details for cadwelding of wires to pipes.

Record Drawing Submittal: Before final acceptance and as a prerequisite to final payment, provide complete, accurate, dimensioned Record "as built" Drawings of the entire system showing the precise location of all anodes, test stations, and routes of connecting cables. Obtain approval of Record Drawings from M.I.T. Project Manager.

Backfilling: Test, check, and protect connections and wiring before backfilling. Backfill in a manner to prevent damage to system. (See Trench Detail C-1)

Testing and Reporting: Provide complete and thorough testing of the installed system and provide additional anodes and alterations as needed to ensure proper performance. Provide detailed written test reports showing measured Performance Data for the system in sufficient detail to serve as basis for future system condition evaluation.

Designer Certification: The Designer of the system shall provide on-site observation during installation of the anodes and test stations, shall report in writing any work not done in

conformance with the Design Documents. Upon completion of the system installation, the Designer shall provide a certified letter stating that the installation has been made properly, is in conformance with the Design Documents, and is performing to provide adequate piping protection.

Warranty: Provide a comprehensive written warranty extending from one year from Date of System Acceptance by M.I.T., to guarantee the proper function of the entire system. Warranty shall provide all labor, materials, and costs for complete replacement of all failed and improperly performing work and components with new work and components, and shall provide for uncovering and recovering defective work and components

2.9 Metering

A. Scope of Work

The MEP contract for the MIT building construction or renovation project shall furnish all labor, materials, transportation, equipment, accessories and services necessary for the installation of meters and field devices necessary for the real-time remote acquisition metering data acquisition system for MIT Utilities services to the building. All shop drawings, equipment configuration sheets and installation drawings shall be approved by the MIT utilities metering team.

B. Scope of Supply

The MEP contract shall supply the following metering data acquisition system components:

1. Static and Differential Pressure Transmitters
2. Resistance Temperature Detectors, Temperature Transmitters
3. Chilled Water Flow Meters
4. Domestic Water Meters
5. Steam Flow Meters
6. Hot Water Flow Meters
7. Electric Energy Meters
8. Compressed Air Meters
9. Building Ethernet Metering Data Acquisition Panel
10. MIT Ethernet Jack & IP address

C. Related Work Specified Elsewhere

1. Electrical Work
2. Mechanical Work

D. Work by Others

The following work shall be provided by the MIT Utilities Metering Team

1. Approval of locations and manufacturers for meters, pressure and temperature taps and transmitters and data acquisition panels.
2. Approval of shop drawings, equipment specifications, configuration parameters for multi-variable transmitter and sizing sheets for flow elements and installation details.
3. Adjusting of transducer spacing and programming of process variable parameters for metering.
4. Testing and commissioning of metering data acquisition points.

E. Materials and Equipment

Equipment and materials shall be delivered to the site and stored in original sealed

containers. The manufacturers listed in these specifications have been pre-selected to work with the design criteria for metering and remote data acquisition system. No substitutions will be accepted.

F. Submittals

A set of equipment shop drawing data including but not limited to the following, shall be submitted to the Utilities Metering Team for approval:

1. Shop drawings
2. Manufacture's model and catalog data and equipment cuts
3. Configuration sheets for metering system components
4. Piping drawings
5. Conduit routings and wiring diagrams
6. Engineering loads for steam, chilled water, domestic water and electricity.

G. As-Built Record Documents/Drawings

Upon completion of work, the MEP contractor shall furnish to the Utilities Metering Team the following:

1. Record drawings in AutoCAD format showing
2. Locations of Building Ethernet Metering Data Acquisition Panel, meter locations.
3. Wiring diagrams showing external wiring between meters and Building Ethernet Metering Data Acquisition Panel
4. Manufacture's model and catalog data and equipment cuts
5. Configuration sheets for metering system components
6. Calibration certificates
7. Guarantee and warranty information
8. Manufacturer's Operation Manuals
9. Building Ethernet jack number and MIT IP address information

H. Contact Information

Before starting work on designing the metering system, contact the head of MIT's utility metering for a consultation. There may be special requirements for any given installation that require special consideration and possibly a change of equipment or metering location.

I. Site Install Requirements

1. General

- a. Meter Wiring: Building meters shall be wired from the meters to an existing or a new Building Ethernet Metering Data Acquisition panel located within 400 feet of the meters, using shielded twisted pair cables run in EMT conduit. LIQUATITE or similar conduit shall be used within 3 feet of the field located meters in mechanical rooms. Four (4) inch square pull boxes are located at junction points and at least every 50 feet of conduit for tie-in accessibility. The covers of the boxes shall be painted green as a designation for the metering circuits.
- b. Building Ethernet Metering Data Acquisition Panel: The Ethernet Metering Panel shall consist of a 16"Hx20"Wx12"D NEMA 4 enclosure with a locking door. Each panel shall house a 24 volt dc uninterruptible power supply (UPS), a programmable logic controller (PLC) base units for at least 4 analog inputs and at least 4 digital inputs, Modbus master communication card, duplex outlet, fuses, terminal blocks, I/O communications cable, copper ground bus and

interconnecting wiring. The panel shall be a custom configured panel from I&C Engineering.

2. Products

- a. Building Ethernet Metering Data Acquisition Panel shall be a custom configured panel from I&C Engineering.
- b. Meter Wiring: The wiring between the meters and the node control panels shall be shielded twisted pairs and shielded twisted triads. Single pair cables and multi-pair cables shall be 18 AWG or greater.
- c. Electrical Metallic Tubing (EMT) Conduit: Galvanized EMT hot-dip galvanized outside, enameled finish inside.
- d. Liquid-Tight Flexible Conduit: Liquid-Tight Flexible Conduit: continuous lengths of wound and interlocked galvanized steel over which is extruded a polyvinylchloride covering.
- e. Conduit Fittings
 - i. EMT: Fittings : Rain-tight and concrete tight compression type, made of steel with nylon-insulated throat; Gedney Company #7075 W-IT series and 6075W series. Intender type couplings shall not be used.
 - ii. Liquid-Tight Flexible Conduit: Fitting for Liquid-Tight Flexible Conduit: Compression type with a seal to provide a watertight connection with the conduit. Use with locknut type sealing fitting having O-rings or other suitable sealing method to provide a watertight fitting in outdoor or wet areas.
 - iii. Acceptable Manufacturers: Oz/Gedney, RACO or Thomas and Betts.

3. EMT Application

- a. Above Grade Exposed Conduits
- b. EMT shall be used except as otherwise permitted
- c. Conduits for process instruments shall have threaded fittings and watertight connectors

4. Liquid-Tight Application

- a. Liquid tight flexible steel conduit shall be used for connection to motors, and field instruments unless otherwise specified on drawings

5. Instrumentation and Signal Wire and Cable

- a. Single pair instrumentation cable shall be twisted shielded pair, 18AWG or greater, stranded copper, flame-retardant PVC insulated with aluminum/Mylar tape shield and copper drain wire with overall flame retardant PVC jacket. Rated 300 volts, 90oC. Belden 83652 or similar
- b. Multiple pair instrumentation cable for digital (discrete signals) and analog shall consist of individual 18 AWG, twisted pairs as specified above with an overall shield and copper drain wire and flame retardant PVC jacket. Rated 300 volts, 90 degrees C.
- c. 4 conductor wiring for RTD signals shall be 20AWG or greater stranded copper, flame-retardant, PVC insulated, with overall flame retardant PVC jacket. Rated 300 volts, 90oC. Belden 8484 or similar.

6. Other Instrumentation and Signal Wire and Cable

- a. Other instrumentation and signal wire and cable shall be as specified in other sections and as shown on the drawings

7. Wire Markers

- a. Wire Markers: Plastic; Brady, Omni-Grip, slip-on type or T&B machine printed labels

3. MISCELLANEOUS UTILITIES

3.1 Compressed Air

Compressed air is distributed at 80-90 psi. Currently there is minimal capacity available and distribution is limited. As campus demand grows, supply will be increased and metered.

A. Compressed Air Metering

1. Flow Measurement

Compressed air mass flow shall be measured using a Rosemount conditioning orifice plate as the primary flow element combined with a Rosemount 3051S mass flow meter. The flow element design will be handled by Rosemount directly, with the factory mandating the upstream and downstream straight pipe runs required. A KEP Supertroll2 flow meter will be included, programmed for mass flow totalization. The flow meter will be sized for expected maximum building usage.

2. Location of Orifice Plate

The orifice plate shall be inserted into the supply line, before any building line branch take-offs. Installation in a horizontal run of pipe is preferred but if a vertical run is the only option this note will be passed on to Rosemount for design review.

Pipe straight run requirements shall be as follows:

Upstream of the orifice plate: Minimum of two pipe diameters

Downstream of the orifice plate: Minimum of two pipe diameters

3. Temperature Measurement

The temperature measurement will come provided in the Rosemount transmitter and orifice plate package.

4. Flow Output

The Rosemount flow meter will have a 4-20mA mass flow output. This will be wired into a KEP Supertroll2 flow computer. The flow computer will have a Modbus RTU interface that will be wired into a serial Modbus chain running between all respective energy meters in the project, terminating at the metering panel.

5. Sensor Lines (Impulse Lines)

The Rosemount transmitter will be mounted directly to the orifice plate, and as such will not require any sensing lines.

B. Products

1. Flow Element

Rosemount conditioning orifice plate of the diameter sized to capture the operational range of the compressed air load for the building. Rosemount configurations sheets shall be filled out for sizing the orifice plate. The orifice plate shall be fitted between two

ANSI 150# flanges. The contractor shall install flanges in the existing metering loop to accommodate the orifice plate.

2. Pressure Transmitters

Rosemount Model 3051SFC pressure transmitter shall be provided. Transmitter shall be factory calibrated to the designed range of the orifice plate. Transmitter will be directly coupled to the orifice plate and installed in such a way that the manifold valve handles and calibration port are easily accessible. The transmitter will be installed at the 12:00 position in order to negate any condensate collecting on the sensor. Transmitter mfg. order number: 3051TG2A2B21AS5B4Q4J3M5

C. Installation

1. Run a dedicated circuit (120VAC) to the KEP flow computer in EMT conduit. Leave slack in the wiring for connections (to be completed later). Provide a local disconnect (light switch) in order to allow for safe meter servicing. Run Liquid –Tight Flexible conduit from the flow computer to the transmitter. Twisted shielded wire to be used from the KEP to the flow transmitter. Modbus wiring to be run from closest available Modbus string using twisted shielded cable.

3.2 Fire Detection and Alarm

Fire detection and installed fire panel is a building system. Fire detection systems also include any heat tracing and associated monitoring.

3.3 Tel/Data

Tel/data work is directed and wired by IS&T. Utilities provides consulting for manholes and ductbanks for distribution.

3.4 Emergency Power

Emergency power generation is a building system.

3.5 Lab Waste

Lab waste master plan is under development and will define requirements for permitting and reporting.

3.6 NOx Emissions

NOx data must be reported during the design phase with anticipated start date so that any stationary fuel burning equipment is confirmed to be within the campus 25 ton NOx limits. The campus has a 5 year rolling 25 ton NOx limit on stationary fuel burning equipment.

4. 331000 - WATER UTILITIES

4.1 Domestic Water Information

Domestic water is provided to all buildings on campus by the City of Cambridge Water Department (CWD) either directly or by tapping into the campus distribution network.

The Utility Domestic Water system starts at the shutoff valve at the city main and ends at the building back flow preventers. Beyond this point, refer to Division 23.

CWD maintains a network made up of 200 miles of pipeline, 15,000 service connections, 1,800 fire hydrants and 4,500 valves.

City water pressure varies with the season between 40 psig and 60 psig.

4.2 Domestic Water Design Issues

Domestic water pipes with less than 4-1/2 feet of cover must be insulated and analyzed for potential traffic load impacts and potential for freezing. Greater than 5 feet of cover is preferred.

Whenever possible, water mains shall be installed at least 10 feet horizontally from any existing or proposed sewer. If existing conditions prevent a lateral separation of 10 feet, the main should be installed in a separate trench or if it is laid in the same trench it is located on an undisturbed earth shelf on one side of the sewer. The invert of the water main should be at least 18 inches above the top of the sewer. Whenever sewers must cross under water mains, the sewer shall be laid at such an elevation that the top of the sewer is at least 18 inches below the bottom of the water main.

Utility warning tape shall be installed to provide warning and identification of buried piping. Tape shall specify “Cambridge Water” in the street. For water lines on campus, use color-coded detectable utility marking tape.

All valves servicing domestic water on MIT property shall be clockwise to close and counter clockwise to open.

Distribution system pipe shall be a minimum of 8 inches in diameter. Mains shall be sized so the velocity is in the range of 2.5 to 5.0 feet per second.

Assume a minimum trench width of pipe diameter plus 2 feet, with a minimum of 3 feet for water main installation. See typical pipe trench detail C-1.

Dead ends should be minimized or eliminated by the looping of all water mains wherever practical.

Line valves shall be spaced at not more than 500 feet as determined by the CWD.

Water service to properties shall consist of incorporation into the main, copper service tubing, and a curb stop at the property line. See detail C-7. Service boxes supplied shall be “Buffalo” type, American manufactured, of a telescopic type with a length from 4 feet to 5 feet.

Redundant water service (feeds) need to be provided in any new facility considered critical during emergency situations.

CWD will provide Neptune Trident meters (High Performance (HP) Turbine meter or Tru/Flo Compound meter) for pipe sizes up to 2 inches inclusive. In addition to the physical meter, transmitter (Tricon transmitter by Neptune) is included that is preprogrammed to CWD standards.

Domestic water flow on non CWD meters (MIT informational meters reporting through MIT’s PI system) shall be measured using ultrasonic transducers as the primary flow element combined with the GE AT600 flow meter. GE will recommend the design parameters.

Pressure measurement will be conducted if requested through PSI taps that will be installed before any process take-offs. Sensor lines from the pressure taps will be wired to two Rosemount Model 3051 Gauge pressure transmitters that have been factory calibrated to a range of 0-150 PSIG. Transmitter will be coupled with a 306 two-valve manifold. Transmitter order number is: 3051TG2A2B21AS5B4Q4J3M5. Manifold order number is: 0306RT22AA11.

Install dedicated water meters for cooling tower makeup and in-ground irrigation systems. These meters are not sub-meters to a main meter. These meters shall be fed directly from the water service entry, separate from the rest of the building, upstream of the domestic water meter. These meters are used to facilitate the tracking of sewer rebates with the city.

The CWD should be contacted regarding water quality and determine if additional pre-treatment is required to correct any hardness or corrosive issues with city water.

Pipe, valves and fittings for domestic water and fire protection use should be confirmed with MIT Utilities.

4.3 Domestic Water Metering

A. General

1. Flow Measurement

Metering shall be provided to measure consumption of domestic water use to the building, as well as water not flowing into the city sewer system such as that used for irrigation. In new installations, the Cambridge Water Department (CWD) will furnish Neptune Trident meters for pipe sizes up to and including 2 inches. Meters greater than 2 inches in size will be furnished by the MIT project and shall be of the Neptune HP Turbine Meter series. Meters larger than 2 inches in size shall be installed with a strainer. Test Ports shall be provided in installations of meters that are 4 inches or larger. All meters shall display readings in Cubic Feet units.

2. Location of Meter

All meters shall be installed within the building, free from exposure to freezing. The meter shall be accessible for ease of reading.

3. Irrigation Meter

Meters shall be furnished and installed in a separate flow stream parallel to the building meter.

4. Strainers and Test Port

All meters shall be provided with strainers upstream of the meter. Test ports shall be provided downstream of the meter on installations of meters 4" and larger. The test port shall be equipped with a full port ball valve and a 2 1/2" M hose tread test port outlet, located so as to allow the connection of a fire hose.

5. Automatic Meter Reading

The Neptune meters shall be fitted with an Automatic Meter Reading communication option. The specific communication option shall be specified by the MIT Utilities group. By default, this will be a 4-20mA signal ranged for the entire flow span of the meter.

B. Non "City of Cambridge" billing meters

1. Flow Measurement

The meter will match the current billing meter make and model, including 4-20mA analog output for connection to the MIT metering system

2. Location of Meter

All meters shall be installed within the building, free from exposure to freezing. The meter shall be accessible for ease of reading.

4.4 Fire Protection Information

MIT's fire protection goal is to provide 100% coverage (including electric rooms) in all of its facilities. In existing buildings, MIT seeks to bring renovated areas into conformance with Institute standards through a strategy of determining the prudent course between achieving higher levels of fire protection and budgetary responsibility.

MIT owns and operates an independent campus wide fire protection loop. System operating information and system mapping is the responsibility of Facilities.

MIT has two (2) Campus Fire Main Loops (West Campus and Main Campus). Flow hydrants throughout the Campus and connected to the Campus Fire Main Loops are for used for the flow and flow measurement of water during a flow test. Backflow preventer devices are not required when connect to the Campus Fire Main Loop.

West Campus Fire Main Loop – fire main is controlled by three (3) fire pumps and they are located in Building W34, W51 and W79. W34 and W79 are electrical driven horizontal split case fire pump. W51 is diesel driven horizontal split case fire pump. West Campus Fire Main Loop is

maintained at 175 PSI supply pressure. A pressure reducing valve station with strainer shall be provided for buildings connect to the West Campus Loop. Connected to the West Campus Fire Main Loop buildings are W1, W2, W4, W7, W15, W16, W33, W34, W35, W46, W51, W51C, W51D, W61, W70, W71, W84 and W85.

Main Campus Fire Main Loop – fire main is controlled by two (2) fire pumps and they are located in Building N16B. Both fire pumps are electric driven horizontal split case fire pump. Only one pump operates on a loss of campus fire main pressure, the other serves as a backup. Main Campus Fire Main Loop is maintained at 145 PSI supply pressure. Connected to the Main Campus Fire Main Loop buildings are 1, 2, 3, 4, 5, 6, 6C, 7, 7A, 8, 9, 10, 11, 12, 13, 14, 16, 17, 18, 24, 26, 31, 32, 33, 34, 35, 36, 37, 38, 39, 41, 42, 42C, 43, 46, 48, 50, 54, 56, 57, 62, 64, 66, 68, N16, W20, W31 and W32.

Portions of the campus are still fed from city water. Water pressure on campus can vary significantly from day to night and from season to season. Pressure ranges from 40 psig to 60 psig.

The Utilities Fire Protection system starts at the fire protection pumps and ends at the building wall. After this point, refer to Division 21.

4.5 Fire Protection Design Issues

Dead ends should be minimized or eliminated by looping of all mains when practical. When dead ends occur, a blow off valve should be installed for flushing purposes. Blow off valves and hydrants must be protected from operating pressures in excess of 150 psi by a normally closed gate valve or PIV.

No fire service line shall be laid in the same trench with any other public or private utilities, except a water service pipe or within 10 feet of a sewer. Water mains designated as transmission mains shall not be tapped for fire service, except when approved by the Cambridge Water Department (CWD).

Cross-connections and potential cross-connections require backflow preventers.

All pipe and appurtenances used for fire protection systems must have Factory Mutual approval.

Fire Protection piping shall be buried with a minimum of 5 feet of cover to top of pipe.

Utility warning tape shall be installed to provide warning and identification of buried piping. Tape shall specify “MIT Fire Protection”. Use color-coded detectable utility marking tape.

Gate valves and post indicator valves shall have a rated operating pressure which is greater than the system design operating pressure.

All valves on MIT property shall be clockwise to close and counter clockwise to open.

Free-standing PIVs are preferred unless site logistics dictate otherwise. The design specification should include details of PIVs, including manufacturer, make, and model.

Distribution system pipe shall be a minimum of 8 inches in diameter and pipe used for hydrant branches shall be a minimum of 6 inches in diameter. Mains shall be sized so the velocity is in the range of 2.5 to 5 feet per second.

Assume minimum trench width of pipe diameter plus 2 feet, with a minimum of 3 feet for water main installation. See typical pipe trench detail C-1.

Hydrants are to be placed at approximately 500 foot intervals. Normal placement is between properties, along the property line if possible. Fire hydrant model and locations need Cambridge Fire Department approval. See Detail C-8.

All fire protection appurtenances must be reviewed and approved by MIT Facilities.

Fire protection services are not to be metered.

Water supply for the system shall be provided from either a campus loop or directly from city water. Pipe used for hydrant branches shall be at least 6 inches in diameter. See Detail C-8. Gate valves shall be rated for 200 psig. Butterfly valves shall be rated 150 psig and hydrants shall be rated for 150 psig.

New building alarms shall connect to the MIT Central Fire station in Operations & Maintenance including underground duct banks, manholes, fiber optic cable, copper cable and radio box.

Restrained joints shall be installed at all joints, fittings, hydrants, sleeves, and valves. Thrust blocks shall be included at all changes in direction including tees and hydrant branches.

4.6 Quality Assurance

Testing: Hydrostatic tests at minimum 2 times working pressure for 2 hours.

4.7 Products

Water Service Piping Systems:

1. Application: Water service piping for buildings.
2. Piping may include: Ductile iron.
3. Valves: Suitable for service.
4. Anchorages: Suitable for service.

4.8 Installation

Install materials and systems in accordance with manufacturer's instructions and engineer's approved submittals. Install materials and systems in proper relation with adjacent construction. Coordinate with work of other sections.

After a section of the main has been pressure tested, the contractor is to flush and disinfect the completed main with the results submitted to the CWD. Backfill and protect work from damage.

5. 333000 - SANITARY SEWERAGE UTILITIES

5.1 Sanitary Sewer Information

The City of Cambridge DPW maintains the sanitary system which includes sewer and drain collection. The sewer always discharges into the Massachusetts Water Resource Authority (MWRA) collection network where it has been fully separated from the drain system.

The city's system also includes combined catchments. During significant rain storms combined sewer systems may fill up beyond their capacity with a mixture of sanitary waste and rain water. A combined sewer overflow (CSO) acts like a relief valve allowing sewerage to discharge into waterways instead of backing up into homes, businesses and streets. Both the Charles River and Alewife Brook receive discharges from Cambridge CSOs at 11 locations. Cambridge is working to reduce and eliminate CSO discharges by separating systems whenever possible.

Improved on-site storm-water management helps mitigate CSO issues.

The City and the MWRA limit temperature, pH, and various pollutants from discharges to the City Sewer System. Connections to the City Sanitary Sewer System require a Sewer Use Discharge Permit from the as well as a Sewer Connection Permit issued by the City of Cambridge.

The Utility Sanitary Sewer system starts at the building wall and ends at the tap into the City Main.

5.2 Sanitary Sewer Design Issues

All sanitary system elements shall be designed in compliance with the current City of Cambridge Department of Public Works (DPW) standard specifications or other guidelines as directed by that agency. Comply with all local code issues for distance between services, including City of Cambridge DPW "Wastewater and Stormwater Drainage Use Regulations" and City of Cambridge Municipal Code 13.16 for Wastewater and Stormwater Drainage System.

Excavated soil is likely to be considered contaminated under Massachusetts Contingency Plan (MCP). Comply with all requirements of the MCP.

Whenever possible, sewer pipe shall be installed at least 10 feet horizontally from any existing or proposed water main. If horizontal separation is not possible, the pipe should be installed in a separate trench or on an undisturbed earth shelf located on one side of the water main. The top of the sewer main should be at least 18 inches below the invert of the water main.

Assume minimum trench width of pipe plus 2 feet with a minimum of 3 feet for sewer pipe installation. See Detail C-1.

Coordinate the design with existing services and work of other disciplines and other site designers. Utilize test pit data and select test pit locations to identify potential interference location with existing services.

Slope is to be constant between manholes and be based on a minimum velocity of 2 feet per second. Maximum slope is 0.1 foot /foot.

Lateral building services shall be a minimum of 6 inches in diameter.

Design safeguards against backflow for all basement services. Backwater valves and cleanouts must be located for ease of operation and accessibility.

Interior drop manholes should be installed for vertical drops greater than 2 feet. Refer to Detail C-13 and C-14.

Pipelines are not to be used as conductors for trench drainage during construction.

New sewer trunk mains shall be a minimum of 10 inches in diameter.

Use 4 foot diameter manholes for pipes up to 24 inches. See Detail C-12.

Precast bases shall be supported on a compacted level foundation of $\frac{3}{4}$ inch crushed stone at least 12 inches thick.

All joints between concrete sections shall be watertight.

Connection of sewer pipe to manhole shall be made using mechanical connections. See Detail C-12, flexible manhole sleeves.

Distance between manholes should generally not exceed 400'.

Manhole frames shall be concentric with top of the manhole structure and in a full bed of mortar so that the space between the top of the brick and mortar and the bottom of the flange of the frame shall be completely filled and made watertight. The upper section of the underground structure shall be eccentric to the lower sections to facilitate ladder installation and access.

The inverts shall conform accurately to the size of the adjoining pipes. Side inverts shall be curved and main inverts shall be laid in smooth curves of the longest possible radius, which is tangent to the centerlines of adjoining sewers.

Provide adequate venting and overall design for gas and sand interceptors and grease interceptors.

Connections to the City Sanitary System require a “Sewer Connection Permit” application to be filed with the City of Cambridge DPW.

5.3 Sanitary Sewer Quality Assurance

See 2.4 above.

5.4 Sanitary Sewer Products

5.4.1 Underground Structures and Manholes

Refer to Appendix D for utilities details and manhole details.

For Drop Manholes: An interior drop manhole should be used when the elevation drop is greater than 2 feet between the pipelines.

Use 4-foot diameter manholes for pipes up to 24 inches.

Precast Bases:

1. All manholes shall have precast concrete bases at least 6-inches thick for 4-foot diameter manholes and 8-inches thick for larger manholes.
2. The precast bases shall be manufactured to contain wall openings of the minimum size to receive the ends of the pipes.
3. Precast bases shall be supported on a compacted level foundation of 3/4 inch crushed stone at least 12-inches thick.

Manhole walls shall be precast concrete sections conforming to the applicable requirements of ASTM “Tentative Specifications for Precast Reinforced Concrete Manhole Sections,” Designation C478.

The top conical section shall have a wall thickness not less than 5-inches at the bottom and wall thickness of 8-inches at the top. The conical section shall taper from a minimum of 48-inches diameter to 24-inches diameter at the top.

All joints between concrete sections shall be watertight.

Gaskets for sealing the joints between manhole sections shall be of petroleum resistant materials of a special composition having a texture to assure a watertight and permanent seal. The gasket shall be of a composition and texture, which shall be resistant to sewage, industrial wastes, petroleum products, and groundwater.

Connection of sewer pipe to manhole shall be made using mechanical connections.

1. Flexible pipe-to-manhole connectors shall be Kor-N-Seal or equal.

Distance between sanitary sewer manholes should generally not exceed 400 feet.

Frames and Covers:

1. Manhole frames shall be concentric with top of the manhole and in a full bed of mortar so that the space between the top of the brick and mortar and the bottom of the flange of the frame is completely filled and made water tight.
2. Frames and covers shall have a 24-inch diameter clear opening, 7 inches tall and shall be manufactured by EJ Group Inc, Model 1040A (non-locking), or equal.
3. Frames and covers shall be of cast iron with diamond cover surface and designed for H-20 heavy duty traffic loading. The casting shall meet the AASHTO M306 proof load, and the minimum loading criterion is 40,000 lbs.
4. Covers for all structures shall have the word "SEWER" permanently cast into the surface.

The inverts shall conform accurately to the size of the adjoining pipes. Side inverts shall be curved and main inverts shall be laid in smooth curves of the longest possible radius, which is tangent to the centerlines of adjoining sewers.

Manhole steps for precast reinforced concrete barrel sections shall be cast in with barrel sections and manufactured from steel encapsulated with molded copolymer polypropylene plastic step.

5.4.2 Piping

Sanitary Sewerage Systems include sewerage piping and systems for building wastes.

1. Pipes and Fittings:
 - a. Pipe Class: SS.
 - b. Reinforced Concrete Pipe (RCP): 12 inch and Larger to ASTM C76, Class III/Class IV Reinforced Concrete Pipe (RCP) with rubber gasket joints to ASTM C443.
 - c. Polyvinyl Chloride (PVC) Pipe and Fittings 4 to 15 inch: to ASTM D3034, Polyvinyl chloride pipe, including those required for stubs, shall conform to ASTM Standard Specifications for Type PSM PVC Sewer Pipe and Fittings. PVC pipes shall have maximum pipe diameter to wall thickness ration (SDR) of

35.

- d. Polyvinyl Chloride (PVC) Fittings 18 to 27 inch: to ASTM F679, Polyvinyl chloride fittings shall conform to ASTM Standard Specifications for Type PSM PVC Sewer Pipe and Fittings.
- e. Polyvinyl Chloride (PVC) Joints: to ASTM D3212, joints shall be push-on bell and spigot joints using elastomeric ring gaskets, gaskets shall be a composition and texture which is resistant to common ingredients of sewage and industrial wastes, as well as petroleum products (oil, gasoline, etc.) and ground water.
- f. Pipe shall be tested by the flat plate deflection method at a minimum of 45 psi at 5 percent deflection in accordance with ASTM D2412.
- g. Standard laying lengths of pipe shall be either 13 or 20 feet.
- h. No single piece of pipe shall be laid unless it is generally straight. The center line of the pipe shall not deviate from a straight line drawn between the centers of the openings at the ends of the pipe by more than 1/16 inch per foot of length.
- i. Assume minimum trench width of pipe diameter plus 2-feet with a minimum of 3 feet, for sewer pipe installation see Appendix B - TYPICAL PIPE TRENCH DETAIL.
- j. Slope is to be constant between manholes and be based on minimum velocity of 2 feet per second. Following are minimum slopes for PVC pipe (n=0.011):

Size (inches)	Minimum Slope (ft/foot)
8	0.0040
10	0.0028
12	0.0022
15	0.0017
18	0.0012
21	0.0010
24	0.0008
Maximum slope	0.1 ft/foot

2. Pipe and fitting materials may include:

- a. PVC.
- b. Reinforced concrete.

3. Bricks:

- a. Brick shall conform to the applicable requirements of ASTM Standard Specification for “Sewer Brick (made from clay or shale)”, Designation C32, for Grade SA, hard brick, latest revision.
- b. The mortar for brickwork shall be composed of Type II Portland cement and sand in the proportions of 1:2.
- c. The sand shall comply with the “Standard Specifications” for “Fine Aggregate”,

for concrete masonry.

4. Crushed stone or sand shall be used as pipe bedding, depending on pipe type.
5. Compacted sand shall be used from pipe invert to 6 inches above the pipe crown.
6. Enough sand shall be placed between the pipe and the sides of the trench, and thoroughly compacted, to hold the pipe in correct alignment.
7. During construction, open ends of pipe and branches shall be closed with polyvinyl chloride stoppers secured in place in an acceptable manner.
8. Pipelines shall not be used as conductors for trench drainage during construction.
9. Design safeguards against backflow for all basement services.
10. Sleeves, Couplings, Gaskets and Valves: Suitable for service.
11. Building Services: Lateral building services shall be a minimum of 6 inch diameter.
12. Cleanouts and Catch Basins: Suitable for service.
13. Connections to the City Sanitary System: Require a “Sewer Connection Permit” application to be filed with the City of Cambridge DPW.

5.5 Sanitary Sewer Installation

Install materials and systems in accordance with manufacturer's instructions and approved submittals. Install materials and systems in proper relation with adjacent construction. Coordinate with work of other sections.

Where connections are made to existing systems, rout out old drainage lines.

Test for proper operation. Clean and protect work from damage.

6. 334000 - STORM DRAINAGE UTILITIES

6.1 Storm Drainage Information

All stormwater elements within public property are designed in accordance with City of Cambridge, Department of Public Works (DPW) specifications. All modifications or connections to a public drainage system require review and approval by the Cambridge DPW, and compliance with their latest regulations.

Refer to “Wastewater and Stormwater Drainage Use Regulations” at the DPW website. Refer to Section 1.

All designs must comply with City of Cambridge Stormwater Management Plan and National Pollutant Discharge Elimination System (NPDES) regulations. Any changes or additions in discharges from MIT outfalls could potentially require Cambridge Conservation Commission approval. All modifications or connections to a public drainage system will require review and approval by the Cambridge DPW, and must be in compliance with their latest regulations.

Any modifications or additions to MIT owned and operated drainage system outfalls require National Pollutant Discharge Elimination System (NPDES) permitting. MIT currently has one master NPDES permit which governs several outfalls, which should be amended as required

The City requires removal of 65% of phosphorus in stormwater generated by new projects with an existing stormwater discharge to the Charles River, and removal of 100% of phosphorus in stormwater generated by new projects with a new stormwater discharge to the Charles River.

Refer to the Environmental, Health, and Safety Thematic Folder for additional regulatory guidance regarding stormwater system design on the MIT campus.

Improved on-site storm-water management helps to mitigate CSO issues.

The Utilities Storm Drainage system begins at the building wall, and ends at the tap into the City Main.

6.2 Storm Drainage Design Issues

Pipes located on public property shall have the following dimensions and features:

1. New storm drain trunk mains shall be a minimum of 15 inch diameter.
2. Catchbasin laterals shall be a minimum of 10 inch diameter.
3. Building service pipes shall be a minimum of 6 inch diameter.
4. Pipe sizes shall be calculated based on achieving self-cleaning velocities during the design storm.
5. Catchbasins shall connect directly to manholes.
6. Refer to City Municipal Code Chapter 13.16 for WASTEWATER AND STORMWATER DRAINAGE SYSTEM information. Refer to "Wastewater and Stormwater Drainage Use Regulations" dated March 31, 2008. This information is available at the DPW website. All stormwater elements within public property shall be designed in accordance with the current City of Cambridge Department of Public Works (DPW) Standard Specifications.

Pipes located on MIT property shall have the following dimensions and features:

1. Pipes which have a diameter less than 12 inches shall be Polyvinyl Chloride (PVC) SDR 35 or heavier as required. Pipes with a diameter of 12 inches and larger shall be reinforced concrete pipe (RCP).
2. Generally, class III concrete pipe is adequate when the pipe has at least 2.5 feet of earth cover. Where 2.5 feet of earth cover is not achievable, Class IV or heavier may be required. The design engineer shall be responsible for determining and specifying the pipe class.

Whenever possible, roof drains shall discharge to landscaped areas in order to increase runoff times of concentration and enhance water quality. Roof drain discharges shall not be routed across walkways or other areas where frozen water would create a safety hazard.

Pipe sizes shall be calculated based on achieving self-cleaning velocities during the design storm.

Inverted siphons should not be designed into stormwater systems to minimize maintenance issues.

Pipes connecting into manholes and catch-basins shall end flush with inside interior wall and all openings around pipe entrances and lift holes shall be filled with non-shrink grout. See Detail C-2.

On-site stormwater management shall be designed using Best Management Practices (BMPs).

Drywells shall not be used to accept drainage from large areas such as parking lots.

Manholes shall be precast with a 4 foot inside diameter for drain pipes up to 30 inches O.D. Manholes shall be 5 foot inside diameter for drain pipes up to 44 inches O.D. See Detail C-3.

Coordinate the design with existing services and work of other disciplines and other site designers. Utilize test pit data and select test pit locations to identify potential interference location with existing services.

6.3 Storm Drainage Quality Assurance

See 2.4 above.

6.4 Storm Drainage Products

6.4.1 Underground Structures with Solid Covers

Concrete drain structures shall be precast four feet inside diameter for drain pipes up to 30 inch outside diameter. Concrete drain structures shall be five feet inside diameter for drain pipes up to 44 inch outside diameter.

Precast Concrete:

1. Precast reinforced concrete drainage structure sections shall conform to the applicable requirements of ASTM C478, latest revision.
2. Concrete shall have a minimum 28-day compressive strength of 4,000 psi, utilizing Type II Portland cement.
3. Reinforcement steel shall be intermediate grade, ASTM A615, and deformed in accordance with ASTM A615.
4. Welded wire fabric shall conform to ASTM A185. Manholes and drainage structures

shall be designed to withstand AASHTO HS-20 loading.

Four foot diameter drainage structures shall have a minimum wall thickness of five inches and bottom minimum thickness of eight inches. Five foot diameter drainage structures shall have a minimum wall thickness of six inches and minimum bottom thickness of eight inches.

Frames and Covers:

1. Manhole frames shall be concentric with top of the manhole and in a full bed of mortar so that the space between the top of the brick and mortar and the bottom of the flange of the frame is completely filled and made water tight.
2. Frames and covers shall have a 24-inch diameter clear opening, 7 inches tall and shall be manufactured by EJ Group, Inc., Model 1040A, or equal.
Frames and covers shall be of cast iron with diamond cover surface design and designed for H-20 Heavy Duty traffic loading. The casting shall meet the AASHTO M306 proof load, and the minimum loading criterion is 40,000 lbs.
3. Covers for all structures shall have the word "STORM" permanently cast into the surface.

Drainage structure steps for precast reinforced concrete barrel sections shall be steel encapsulated with molded copolymer polypropylene plastic step.

All drainage structures shall have a 4 foot sump for sediment collection.

Pipes connecting into concrete drain structures shall end flush with interior wall and all openings around pipe entrances and lift holes shall be filled with non-shrink grout.

6.4.2 Underground Structures and Catchbasins

For typical catchbasin configuration, see Appendix G - PRECAST CONCRETE CATCHBASIN.

Precast concrete catch basin shall conform to the applicable requirements of ASTM C478 or ASTM C858, latest revision and designed to withstand AASHTO HS-20 loading.

Precast concrete sumps, 6 foot minimum depth, shall conform to the applicable requirements of ASTM C478. Wall sections shall have a minimum wall thickness of six inches.

Frames and Grates:

1. Manhole frames shall be concentric with top of the manhole and in a full bed of mortar so that the space between the top of the brick and mortar and the bottom of the flange of the frame is completely filled and made water tight.
2. Frames shall have a 23 ³/₄ -inch diameter clear opening, 8 ¹/₈ inches tall and shall be manufactured by East Jordan Iron Works, Model 1040M3, or equal.
3. Frames and grates shall be of cast iron with cover surface and designed for H-20 heavy

duty traffic loading. The casting shall meet the AASHTO M306 proof load, and the minimum loading criterion is 40,000 lbs.

4. Grates for all structures shall have the word “DRAINS TO WATERWAYS” permanently cast into the surface.

Two 4-inch weep holes shall be provided with each catch basin. The pipe through the catch basin wall shall be PVC and a 1/2-inch mesh 23 gauge galvanized wire shall be secured at the end of the pipe to keep the stone out. Two cubic feet of stone sized 3/4-inch to 1-1/2-inch shall be placed around each weep hole. In areas of contamination or high groundwater, weepholes shall not be provided.

Pipes connecting into catchbasins shall end flush with inside interior wall and all openings around pipe entrances and lift holes shall be filled with non-shrink grout.

For catchbasins located in a paved area, an oil and water separator shall be installed at the outlet pipe. An oil and water separator may be in the form of an elbow down, or a hood specifically manufactured for oil and water separation. The separator shall be removable for periodic flushing and cleaning of drain lines.

All catchbasins shall have a 6 foot deep sump for sediment collection.

6.4.3 Pipe, Joints, and Brick

1. Pipes:
 - a. Pipe Class: SD.
 - b. Reinforced Concrete Pipe (RCP) 12 inch and Larger: to ASTM C76, Class III / Class IV Reinforce Concrete Pipe (RCP) with rubber gasket joints to ASTM C443.
 - c. Polyvinyl Chloride (PVC) Pipe 4 to 10 inch: to ASTM D3034, Polyvinyl chloride pipe, including those required for stubs, shall conform to ASTM Standard Specification for Type PSM PVC Sewer Pipe and Fittings. Pipe shall have a minimum diameter to wall thickness ratio of (SDR) of 35.
 - d. Pipes shall be tested by the flat plate deflection method at a minimum of 45 psi at 5 percent deflection in accordance with ASTM D2412.
 - e. Standard laying lengths either 13 feet or 20 feet.
2. Joints:
 - a. Joints shall comply with ASTM D3212 “Standard Specification for Joints for Drain and Sewer Plastic Pipes Using Flexible Elastomeric Seals”.
 - b. Joints shall be push-on bell and spigot joints using elastomeric ring gaskets. Gaskets shall be a composition and texture resistant to common ingredients of sewage and industrial wastes, petroleum products (oil, gasoline, etc.) and

groundwater.

3. Brick:
 - a. Brick shall comply with the ASTM Standard Specification for “Sewer Brick (made from clay or shale)”, Designation C32, for Grade SA, hard brick.
 - b. The mortar for brickwork shall be composed of Type II Portland cement and sand in the proportions of 1:2. The sand shall comply with the “Standard Specifications” for “Fine Aggregate”, for concrete masonry.

6.5 Storm Drainage Installation

Install materials and systems in accordance with manufacturer's instructions and approved submittals. Install materials and systems in proper relation with adjacent construction. Coordinate with work of other sections. Provide cleanouts.

Connect to above-grade and below-grade drainage systems. Drain system to approved location. Test for proper operation. Clean system out and protect work from damage.

7. 337000 - ELECTRICAL UTILITIES

7.1 Electrical Information

Primary voltage delivered to MIT buildings by the Central Utilities Plant (CUP) is 13.8kV.

The 2.4kV service provided historically is not available for expansion.

Double-ended substations are interconnected on the secondary side to provide redundant transformer capabilities.

All switches in substations are loop connected to the MIT distribution system either at 2.4kV or 13.8kV.

7.2 Utilities Electrical Design Issues

Any interface with the MIT electrical distribution system should be reviewed with the MIT Utilities Group.

Duct-banks to be steel-reinforced concrete encased with 5”, schedule 40 PVC conduits provided. See Details C4, C5, C5A, & C6. Pin new ductbanks solidly to existing manholes and building penetrations

Medium voltage cables installed shall be 15kV, 350 kcmil and EPR 133% insulated. There shall be two radial feeders serving each building through separate manholes if possible. Buildings having critical requirements must have two separate entries into the building. All cables in

manholes and pull-boxes are to be identified using non-corrosive, permanent tags. The cable shall be marked with the location it is coming from and the location it is going to. Within a manhole cables shall be looped once around the interior after entering and once before leaving. Fire-wrap is required for all cables. A list of approved manhole materials is available from the MIT Utilities Group.

Refer to Division 26 for metering requirements.

All penetrations to manholes or buildings are to be made watertight using OZ Gedney water stops for all existing and new cable runs.

All spare conduits need blank plugs as approved by MIT Utilities Group.

Medium voltage load break switches shall be manufactured by G&W Electric Company, no substitutions, and as follows. Each switch shall have the following features:

1. RAM 44-376M-40PI 4way (or as need by MIT facilities) SF6 gas switch.
2. Rated for 15,000 volts.
3. Open stud bushings ICSBO376SF.
4. 42 inch paneled bolted frame.
5. Incoming loop cable: 3-1/C 350 kcmil Cu EPR with shield and insulated 4/0 AWG Cu ground cable.
6. Switches are bottom-fed.

Feeder cable to substation from load break switch shall be 3-1/C 4/0 AWG Cu EPR with shield and insulated #2 AWG Cu ground cable.

There shall be one medium voltage circuit breaker provided for the medium voltage side of each substation transformer.

There shall be one spare position provided for MIT's future use when a new switch is provided.

There shall be two switches provided for each double-ended substation

Configure switch cable connections on first switch as follows:

1. Position 1: incoming loop cable.
2. Position 2: feeder cable to substation first MV vacuum circuit breaker.
3. Position 3: spare.
4. Position 4: Outgoing cable to connect to second switch.

Configure switch cable connections on second switch as follows:

1. Position 1: incoming cable from first switch.

2. Position 2: feeder cable to substation second MV vacuum circuit breaker.
3. Position 3: spare.
4. Position 4: outgoing loop cable.

All switches shall be loop connected to the MIT distribution system at 13,800V.

Switches shall be located in the same room as the substation.

Installation clearance from back and side walls required to be 18 inches.

7.3 Quality Assurance

See 2.4 above.

Devices and Accessories Including Ducts for Communications and Telephone Service: Listed and labeled as defined in NFPA 70, Article 100.

7.4 Products

Cable Tags - Tech Products, Inc. 1" Everlast Indestructible

No substitutions are acceptable.

Use polypropylene tag holders with cable ties. Tag holder length shall be custom as required for cable identification.

Arc & Fire Proofing Tape - Plymouth Bishop 53 Plyarc Arc and Fire Proofing Tape or approved equal

Tape shall be compatible with cable jacket.

Install on all cables that are not located within a raceway

15kV Cable - Okonite 15kV Shielded Power Cable Type MV-105 350 kcmil 133% Insulation Level 105 deg C for underground use in dry or wet conditions

Equivalent Kerite cable will be accepted. No other substitutions are acceptable.

MIT approved contractors shall perform installation of 15kV cable and terminations:

Powerline Contractors or MassBay Electrical Contractors.

Splices and Terminations

Use appropriate (Raychem or 3M) splice or termination kit for specific cable types.

Hand cold layup splices are not acceptable.

Trifurcating splices must include oil stop to PILC cable. Provide new grounding conductor.

5/8kV Cable -

Okonite 5/8kV Shielded Power Cable Type MV-105 133% Insulation Level 105 deg C for underground use in dry or wet conditions

Equivalent Kerite cable will be accepted. No other substitutions are acceptable.

MIT approved contractors shall perform installation of 5kV cable and terminations:

Powerline Contractors or MassBay Electrical Contractors.

Use appropriate Raychem splice or termination kit for specific cable types.

Hand cold layup splices are not acceptable.

SF6 switches - G&W Electric, Inc. - see www.gwelec.com

IR viewport – Fluke CV300 ClirVu Series IR windows - see www.fluke.com

Conduit sealing bushings – OZ Gedney see www.emerson.com

7.5 Installation

Install materials and systems in accordance with manufacturer's instructions and approved submittals. Install materials in proper relation with adjacent construction and with uniform appearance for exposed work. Coordinate with work of other sections.

Test all systems for proper operation.

Restore damaged finishes. Clean and protect work from damage.

8. 337119 - DUCTBANKS

8.1 Ductbank Information

Underground duct banks and related underground utility structures are used to convey medium voltage power cabling, telecomm cabling, and fire alarm cabling on the MIT campus.

8.2 Ductbank Design Issues

Asbestos containing materials must not be used in ductbanks or underground structures.

Project “as-built” documentation for underground structures and building entrances must include cable locations and termination points.

The designer is responsible for selecting and designing all supports, anchors, and racking.

Adequate sumps must be provided within underground structures to permit pumping.

Utilize manufacturers recommended accessories.

Ductbanks shall be of a dimension to meet project requirements, including the following features:

1. Conduits used in ductbanks are to be 5-inch, round, schedule 40 polyvinyl chloride (PVC).
2. For manhole and building foundations, 10 feet of rigid galvanized steel conduit are to penetrate the wall. The galvanized rigid conduit (ductbank) penetrations into the typically

- wet/humid electric manhole should not extend no more than 2” to 3” beyond the manhole wall. The galvanized rigid conduit exposed threads need to be painted with a zinc paint that will prevent rusting. Material for each conduit ground bushing needs to be silicon bronze and the ground should be a #4 solid tin wire to avoid major rusting and corrosion within a year or two. The same O-Z Gedney type conduit seal bushings shall be used in the manhole just as they are in the building. The conduits leading up to the substation room must have stress relief “wedges” that not only seal the spacing around the cables, but support it on long vertical runs.
3. New ductbanks shall be poured into a cutout window in the wall of manholes or building foundations. Refer to Detail C5. Coring shall only be permitted upon approval of MIT Utilities.
 4. Each single conduit in the ductbank shall be separated and completely encased in concrete. See Detail C4.

Ducts shall slope towards manholes and away from building penetrations, including:

1. Conduits shall be laid at a minimum grade of 3 inches per 100 feet.
2. In no case shall conduits be constructed with intermediate low points between structures which will collect water.
3. No isolated low points will be allowed unless reviewed and approved by MIT Utilities and Information Systems and Technology (IS&T).

An application for Grant of Location must be filed with the City of Cambridge Pole and Conduit Commission and approved prior to construction of any ductbank in the public way.

Wherever feasible, electrical and telecommunications ducts are to be constructed within a common trench and ductbank. Building service requirements include:

1. At a minimum, 6 conduits shall be provided for MIT Telecomm/MIT Fire Alarm at each service entry.
2. Two independent and physically separated service entrances shall be provided for new buildings.
3. Service entrances shall be from separate underground structures and from separate ductbank systems.
4. At a minimum, 4 conduits shall be provided for MIT Utility Electric at each service entry.
5. Both ends of the campus medium voltage loop cannot enter through a common underground ductbank.
6. In addition to the requirements of the immediate project, a minimum of 2 spare conduits shall be provided for electrical and 2 spare conduits shall be provided for telecomm.

Refer to Appendix D for details. Ductbanks must be separated before approaching their respective underground structures.

Ductbanks shall be installed so that the top of the concrete is not less than 30 inches below finished grade at the highest points.

Ductbank transitions to building walls and underground structures (including other intersecting ductbanks) shall be designed to prevent shearing and separation.

After completion of ductbanks, all ducts shall be rodded and brushed. Graduated mule tape and blank duct plugs shall be installed.

Manholes should be left completely clean by contractor. MIT requires that their butterfly diagrams are updated by the contractor to show changes due to project work. Contactor must also provide before and after photographs to document the changes.

Manhole entrance requires an aluminum sign to be posted on the manhole throat stating the manhole identification. For example "EMH-XX". Size approximately 2" x 8". Signage should be replaced if missing from an existing manhole.

Manhole entrance requires an aluminum sign to be posted on the manhole throat stating "DANGER High Voltage and Confined Entry Permit Required. Notify MIT Operations Prior to Entry. Call 617-253-1500". Signage should be replaced if missing from an existing manhole.

Joints in horizontal runs of conduits within ducts, may be placed side-by-side, but stacked conduit joints shall be staggered along the run at least 6 inches vertically.

Duct spacers shall be provided in all duct lines to support and maintain spacing of ducts during concrete pour. Spacers shall be placed on centers not greater than 4 feet.

Seals:

1. Where a proposed ductbank is connecting into an existing structure, core existing vault and use link seals to provide water tight connections. Install 10' of steel conduit per earlier requirements.
 - a. For all existing or new conduits which enter underground structures or buildings, the cable/conduit interface shall be sealed with O-Z / Gedney type CSB conduit sealing bushings.
 - b. The conduits and area around building service entrances and underground structure penetrations, conduits are to be sealed with the appropriate Link Seal product.

Horizontal and Vertical Alignment:

1. Changes in vertical or horizontal alignment of a ductbank exceeding a total of 10 degrees shall be long sweep bends having a minimum radius of curvature of 25 feet.

2. Manufactured bends may be used if reviewed and approved by MIT during the design process.
3. The sum bending angles on any single run between manholes shall not exceed 180 degrees.
4. Spacing between electrical manholes shall not exceed 300 feet and spacing between telecommunications manholes shall not exceed 350 feet.

Underground Structures and Vaults

1. Telecom and electrical vaults shall be precast reinforced concrete.
2. Concrete shall be 5,000 psi at 28 days. Reinforcing steel shall comply with AASHTO M31, grade 60.
3. Manhole walls and base slab to be minimum 6 inch thick, top slab minimum 8 inch thick.
4. Entire underground structure exterior is to be damp-proofed.
5. Ground rods shall not be installed through the underground structure floor. Grounding conductors shall exit the vault high on the wall and connected to an external grounding system.
6. The interior dimensions of underground structures and vaults shall be minimum 6 by 9 feet by the required depth.
7. Underground structures and vaults shall be designed to support loading from:
 - a. Piping and appurtenances
 - b. HS-20 loading
 - c. Lateral soil pressures above and below ground water
8. Underground structures and vaults shall have a sump pit 1 foot in diameter and 4 inch deep. The manhole floor shall be sloped to the slump 1/4 inch per foot.
9. Vaults shall be buried a maximum of 1 foot-6 inches.
10. Two pulling eyes shall be provided on each wall with a ductbank window. Pulling eyes shall not be closer than 12 inches to any ductbank window.

Manhole Covers:

1. EJ 3200 Series locking composite cover and frame assembly.
 - a. Cover size shall be at least 32" diameter.
 - b. MIT Utility department approval required if cover size is smaller than 32" diameter.
 - c. Use composite assemblies on MIT property.
 - d. Do not use composite assemblies on city streets or state parks and roadways.
 - e. Cover shall meet MIT electrical, telecom and fire alarm manhole labeling standards.

Conduits (Piping)

1. Conduits shall be manufactured of PVC, Carlon PV-Duct, Type 40, 90 degree UL rated or approved equal.
2. Material shall have a tensile strength of 7,000 psi at 74.3 deg. F, flexural strength of 11,000 psi and compressive strength of 8,600 psi.

Conduit Seal Plugs – Spare Ducts

1. Tyco Electronics Blank Duct Plugs Type JM-BLA or approved equal.
 - a. To be used for spare ducts in manholes and at building entrances.
 - b. All spare ducts shall have pulling tape installed and terminated to duct plug.

Conduit Seal Foam – Existing Cables in Ducts

1. Polywater Corp. FST Foam Sealant or approved equal. To be used on existing cables in manholes and at building entrances.

Conduit Seal Bushing – New Cables in Ducts

1. O-Z/Gedney Conduit Sealing Bushing Type CSB or approved equal
 - a. To be used for new and existing cable installations in manholes and at building entrances.
 - b. Order sealing bushing to match specific cable size used within duct.
 - c. Duct sealing bags similar to Raychem RDSS are not acceptable.

Non-Metallic Cable Racks

1. Underground Devices, Inc. Type “-B” or approved equal
 - a. Attach the racks to the structure using stainless steel hardware.
 - b. Racks shall be designed to support all the cables within the manhole, including spare capacity for future cables.

8.3 Quality Assurance

See 2.4 above.

8.4 Installation

Water and debris must be prevented from entering conduits or manholes during construction. The ends of all conduits shall be plugged with blank duct plugs immediately after they are rodded and brushed clean. When cables are pulled the blank duct plugs can be removed from the utilized conduits and segmented OZ Gedney duct plugs shall be installed in their place. Spare ducts shall remain protected by blank duct plugs.

9. 335000 – STEAM AND CONDENSATE UTILITIES

9.1 Steam and Condensate Information

Steam is delivered to buildings at 190-200 psig entry pressure and 380-450 degrees F depending upon location and proximity to CUP.

No direct CUP steam exposure is allowed for humidification. Steam needed for humidification is to be provided by the building with a separate clean steam generating heat exchanger.

Steam required for process needs is to be provided by the building with a separate steam generating heat exchanger.

All condensate within the utility system must be returned to the Central Utilities Plant.

Pressure reducing station installation is building and project responsibility.

The Utility Steam and Condensate system begins at the CUP and ends at the building isolation valve or PRV. After this point, refer to Section 23.

9.2 Steam and Condensate Design Issues

Steam main drip locations and detailing need to be coordinated with the work of other disciplines and MIT Facilities. Inside of building or walkable tunnel follow HVAC standard for condensate pumping. Underground Utility Systems can inject high pressure condensate into the pumped condensate return using a sparger as shown in drawing M-18.

Ease of installation, maintenance and repair of vaults, tunnels and trenches are important design considerations.

Condensate handling and use of flash tanks, injection quills, pump sets and trapping need to be accounted for and properly located.

Label and identify pitch of piping for proper condensate removal.

Provide proper clearances between steam and condensate piping and other piping and structures.

Thermally insulate all hot lines and surfaces. Completely insulate all system components and surfaces including, without limitation, piping, valves, valve bonnets, flanges, strainers, fittings, expansion joints, special valves, control valves and cocks. Insulation and jacketing thickness shall be based on a 40 year life cycle cost basis. See Details M-1 & MH3.

Comply with the general installation requirements provided by the MIT Utilities Group. See Details M-2, M-3, M-4, M-5, M-6, M-7, M-8, M-9 & C-1. Details are illustrative and will vary depending upon the specific manufacturer providing the product. All prefabricated direct buried

piping to be marine grade and the shrink sleeve enclosures be double sealed in ground water locations.

Provide single trap to hold steam in a heating apparatus or piping system and allow condensate and air to pass. See Detail M-18.

9.3 Steam and Condensate Quality Assurance

The piping system supplier's representative shall be responsible for directing the installation and testing of the conduit system. It shall be certified in writing by the supplier that the representative is technically qualified and experienced in the installation of the systems and has been factory trained to provide field technical assistance. The supplier's representative shall be present during the following work phases:

1. Inspection and unloading
2. Inspection of trench prior to laying of conduit
3. Inspection of expansion loops
4. Inspection of joining of system
5. Hydrostatic Testing (piping)
6. Air test (conduit)
7. Repair of any patchwork
8. Back filling of conduit sections. Examine 100% all welds per radiography examination for underground pipe

9.4 Steam and Condensate Products

MIT's preference is for trench systems when installing new steam and condensate. When a trench is not possible, due to pipe depth or area congestion, direct buried pipe shall be used.

Several recent installations of steam and condensate piping systems are preinsulated composite systems by Thermacore (Duo-Therm 505) and Perma-Pipe (Multi-Therm 500 or 750). We require dryable, drainable, and air-testable systems. The piping, elbows, tees, expansion loops, end seals, gland seals and anchors are all part of the manufacturer's engineered system. The exterior of the selected conduit pipe must be suitable for continuous immersion in groundwater with low pH soils. This requires that the steel conduit's protective coating be of a "marine grade" quality.

All piping in manholes shall be insulated with Aerogel Pyrogel inside removable blankets using jacketing made of PTFE (PureTeflon), 13.5 oz./sq. yd. minimum. Insulation thickness shall be calculated to provide a 90 degree F outer surface temperature. Blankets will be stitched with Kevlar thread with a minimum of .0114", with a break point of 35 lbs. Stitch spacing will be 4 - 6 stitches per inch. Hot rings, staples or wire are not acceptable means of closure. No raw cut edges are to be exposed after installation. Blankets will be secured with Velcro straps and/or D-rings that can withstand temperatures of up to 600 degrees F, and shall be easy to remove and reinstall to allow for pipe maintenance. Valves and joints shall be jacketed separately from straight runs to allow for future maintenance. Steam traps and small gauge pipe shall not be insulated.

Trench tops and trench exteriors shall be waterproofed with “Bituthene 3000” –Rubberized asphalt/polyethylene waterproofing system or MIT approved equal.

Seal all exterior wall piping penetrations above and below grade with “Link Seals” by Thunderline Corporation, Wayne, Michigan. See Details M-13, M-14, M-15 & M-17. Details are not to scale and dimensions will vary with each manufacturer.

Manhole Frames and Covers:

1. Frames and covers shall have a 36-inch diameter clear opening.
2. Frames and covers shall be by Fibrelite, FL75 series. Frames and covers shall be designed for H-20 heavy duty traffic loading. Composite covers shall not be installed in public streets.
3. The covers shall say “MIT STEAM”. Below this text the steam vault number shall appear.
4. All manholes will be vented. Refer to detail MH4.
5. Concrete manholes will have a minimum wall thickness of 10” with steel rebar and sacrificial zinc anodes. Concrete shall have a minimum strength of 5000 psi. The interior and exterior shall be waterproofed with “GCPAT Bituthene 3000” – Rubberized asphalt/polyethylene waterproofing system or MIT approved equal.
6. Steel manholes shall have FRP coating and be pressure tested to 5 psi.

All steam valves less than or equal to 2 inches are to be socket welded. Valves greater than 2 inches are to be butt welded. Preferred manufacturer for steam using manually operated gear is Adams. (See Pipe Index)

9.5 Steam and Condensate Metering

A. General

1. Flow Measurement

For pipe sizes 4” or greater, steam mass flow shall be measured using a flanged GE Panametrics Ultrasonic Flow Tube as the primary flow element combined with the GS868 energy meter. For pipe sizes less than 4”, a GE vortex meter shall be used. The flow meter system shall have a typical turndown ratio of at least 100:1. The flow element design will be handled by GE directly, with the factory mandating the upstream and downstream straight pipe runs required to obtain the turn down ratios needed.

2. Location of Flow Tube

The primary flow element shall be installed on the high pressure side of a building steam PRV. Installation in a horizontal run of pipe is preferred to eliminate residual condensate at low flows. If vertical installation is required, GE must be informed as to that fact and as to direction of flow; up or down.

Pipe straight run requirements shall be as follows:

Upstream of the flow tube: Minimum of twenty pipe diameters for ultrasonic – ten otherwise

Downstream of the flow tube: Minimum of ten pipe diameters for ultrasonic – five otherwise

3. Temperature Measurement

Steam Supply temperature shall be measured using a Rosemount Series 214 100 ohm Platinum Resistance Temperature Detector (RTD) sensor installed in a thermowell. The temperature signals shall be wired to the GE GS868 flow computer to an RTD/4-20mA card provided through GE. If using the GE vortex meter, temperature compensation is already included in the meter.

4. Pressure Transmitter

A Rosemount transmitter shall be provided for the pressure compensation to the GS868 flow computer. It will be ranged 0 – 300 PSIG and wired into the RTD/4-20mA card provided through GE. The transmitter shall be located at a level below the steam supply line. Impulse lines connecting it to the pressure tap in the spool piece shall have a minimum pitch of 1" per foot. If using the GE vortex meter, pressure compensation is already included in the meter.

5. Sensor Lines (Impulse Lines)

Sensor lines from the steam pressure tap to the Rosemount transmitter shall be securely supported and guarded from accidental damage. A 1/4 turn ball valve shall be used for the root isolation valve as well as a blowdown valve. All tubing, piping, fittings, valves, and other wetted parts of the sensing lines shall be grade 316 stainless steel 1/2" tubing, with standard rating of at least 25% above the steam line pressure and temperature, to prevent corrosion damage to the transmitter.

B. Products

1. Flow Element

General Electric flow cell consisting of a flow tube of the diameter sized to capture the operation range of the steam load for the building. GE configurations sheets shall be filled out for sizing the flow tubes. The flow tube shall be fitted with raised ANSI 300# flanges. The contractor shall install flanges in the existing metering loop to accommodate the metering tube. Distance from the up-stream flange to the nearest fitting shall be not less than ten pipe diameters. Distance from the down-stream flange to the nearest fitting shall be not less than five pipe diameters.

2. Temperature Sensor and Thermowell

Temperature Sensor: Rosemount Series 214 RTD Platinum Thin Film Temperature Sensors with thermowells – one in the hot water supply line and one in the hot water return line.

Model No. 214CRTSMB1S4ExxxxSLAT1C3B1G3FAEyyyXW where xxxx = sensor length (Immersion length + head length) and yyy = extension length. Sensor lead termination shall consist of a painted aluminum connection head with flat cover containing six (6) terminals. Adapter shall be spring loaded-type.

Thermo-well: A dedicated thermowell shall be provided for metering. Insertion length shall allow for a penetration to the center of the pipe after allowing for the length of the

weld-o-let. Model Number 114CExxxxTAB3SCyyyBXW where xxxx = immersion length and yyyy = head length. Pipe Mounting Connection: Weld-O-Let Standard 3/4-14" NPT (with Female connector).

3. Pressure Transmitter

A Rosemount Model 3051 Gauge pressure transmitters shall be provided. Transmitter shall be factory calibrated to a range of 0 to 300 PSIG. Transmitter will be coupled with a 306 two-valve manifold and installed in such a way that the valve handles and calibration port are easily accessible.

Transmitter mfg. order number: 3051TG4A02A1AS5M5Q4

Manifold shall be Rosemount Model No. 0306RT22AA11

C. Installation

Run a dedicated circuit (120VAC) to flow meter in EMT conduit. Leave slack in the wiring for connections (to be completed later). Provide a local disconnect (light switch) in order to allow for safe meter servicing. Run Liquid –Tight Flexible conduit from the flow meter to the transducers and RTD sensors. RTD wiring to be 4 conductor 20ga or better. Belden Number: 8484 (4 conductor copper) or better. Coaxial cable to be provided by GE with meter. Both RTD and coaxial may run in the same conduit if needed. Connect transducer w with transducer cable to the flow meter. GE onsite start-up will be included with purchase of meter – they will program and commission meter.

A complete system shall include a pressure transmitter with integral 2 valve isolation manifold connected by close nipples to isolate the sensing lines. The isolation manifold shall be a 316 Stainless Steel Block Type. In addition, the system shall include two root block valves, extended blow down lines with isolation valve and cap. The block valves and isolation valve shall be a single piece ball valve rated for 300PSIG. The pressure sensing ports will be installed at a position that will resist air entrapment and sediment build-up.

10. 336000 – MEDIUM TEMPERATURE WATER UTILITIES

10.1 Medium Temperature Water Information

Supply temperature is reset by CUP based on outside air temperature.

Supply currently provides hot water at 180-240 degrees F but may change if CoGen waste heat becomes the primary generator.

The Utility Medium Temperature Water system begins at the CUP and ends at the building heat exchanger. After this point, refer to Division 23.

10.2 Medium Temperature Water Design Issues

The existing MTW piping system mostly consists of Logstor pre-insulated pipe. It is a preinsulated composite system manufactured to comply with EN 253. It consists of steel piping to

carry the hot water, surrounded by a polyurethane foam, with an outer protective casing of high density polyethylene. Tricon and Perma-Pipe (Xtru-therm) are North American equivalents and should be considered for future projects. Any expansion of an existing system shall match the existing. The piping, elbows, tees, expansion loops, end seals, gland seals and anchors are all part of the manufacturer's engineered system. The exterior of the selected conduit pipe must be suitable for continuous immersion in groundwater with low pH soils. This requires that the steel conduit's protective coating be of a "marine grade" quality.

System design should minimize pipe stress where possible. General installation requirements can be found in Details M-5, M-6, M-7 and C-1.

Design peak delta P at the heat exchangers which serve the building shall be in the range of 5-20 psi on the utility side of the exchanger.

Thermally insulate all hot lines and surfaces. Completely insulate all system components and surfaces including, without limitation, piping, valves, valve bonnets, flanges, strainers, fittings, expansion joints, special valves, control valves and cocks. See Detail M-1.

Provide adequate clearances to other piping systems and structures. Exterior wall piping penetrations are detailed in M-15 and M-16.

Arrange hot water supply and return piping so as to minimize heat transfer to chilled water piping.

Provide provisions for cleaning and flushing of piping in system design. Provide provisions for leak detection.

10.3 Medium Temperature Hot Water Quality Assurance

The piping system supplier's representative shall be responsible for directing the installation and testing of the conduit system. It shall be certified in writing by the supplier that the representative is technically qualified and experienced in the installation of the systems and has been factory trained to provide field technical assistance. The supplier's representative shall be present during the following work phases:

1. Inspection and unloading
2. Inspection of trench prior to laying of conduit
3. Inspection of expansion loops
4. Inspection of joining of system
5. Hydrostatic Testing (piping)
6. Air test (conduit)
7. Repair of any patchwork
8. Back filling of conduit sections.

10.4 Medium Temperature Hot Water Metering

A. General

1. Flow Measurement

Hot water mass flow shall be measured using a flanged GE Panametrics Ultrasonic Flow Tube as the primary flow element combined with the DF868 energy meter. The flow meter system shall have a typical turndown ratio of at least 400:1. The flow element design will be handled by GE directly, with the factory mandating the upstream and downstream straight pipe runs required to obtain the turn down ratios needed.

2. Location of Spool Piece

The spool piece shall be inserted into the supply line, before any building chilled water pumps or line branch take-offs. Installation in a horizontal run of pipe is preferred but if a vertical run is the only option this note will be passed on to GE for design review.

Pipe straight run requirements shall be as follows:

Upstream of the Flow Cell: Minimum of ten, preferably twenty pipe diameters

Downstream of the Flow Cell: Minimum of five, preferably ten pipe diameters

3. Temperature Measurement

Hot water supply and return temperatures shall be measured using a Rosemount series 214 100 ohm platinum resistance temperature detector (RTD) sensor, or similar, installed in a thermowell. The thermowell locations shall be provided so as to record temperature of the supply and return service as they enter and exit the building. Each RTD will be wired directly to the DF868 energy meter to a supplied dual channel RTD input card.

4. Flow Output

The GE hot water energy meter will have a Modbus RTU card supplied with the meter. This will be wired into a serial Modbus chain running between all respective energy meters in the project, terminating at the metering panel.

5. Pressure Measurement

Hot water supply and return pressure shall be provided for managing building distribution. The PSI taps shall be installed in supply & return lines before any process take-offs. The two analog points will be wired into the two 4-20 mA analog inputs in the DF868 energy meter to a supplied dual channel 4-20mA input card.

6. Sensor Lines (Impulse Lines)

Sensor lines from the pressure taps to the Rosemount pressure transmitter shall be securely supported and guarded from accidental damage. All tubing, piping, fittings, valves, and other wetted parts of the sensing lines shall be 316 SS ½" tubing.

B. Products

1. Flow Element

A General Electric Flow Cell consisting of a flow tube of the diameter sized to capture the operational range of the hot water load for the building. GE configurations sheets shall be filled out for sizing the flow tubes. The flow tube shall be fitted with raised

ANSI 150# flanges. The contractor shall install flanges in the existing metering loop to accommodate the metering tube. All associated coaxial cable will also be provided in sufficient length to connect the flow element to the DF868 energy meter, not more than 100 cable feet distant.

2. Pressure Transmitters

Two Rosemount Model 3051 Gauge pressure transmitters shall be provided. Transmitter shall be factory calibrated to a range of 0 to 150 PSIG. Transmitter will be coupled with a 306 two-valve manifold and installed in such a way that the valve handles and calibration port are easily accessible. A 1/4 turn ball valve shall be used for the root isolation valve as well as a blowdown valve.

Transmitter mfg. order number: 3051TG2A2B21AS5B4Q4J3M5

Manifold mfg. order number: 0306RT22AA11

3. Temperature Sensors, Thermowells and Temperature Transmitters

a. Temperature Sensor

Two Rosemount Series 214 RTD Platinum Thin Film Temperature Sensors with thermowells – one in the hot water supply line and one in the hot water return line.

Model No. 214CRTSMB1S4ExxxxSLAT1C3B1G3FAEyyyXW where xxxx = sensor length (Immersion length + head length) and yyy = extension length.

Sensor lead termination shall consist of a painted aluminum connection head with flat cover containing six (6) terminals. Adapter shall be spring loaded-type.

b. Thermowell

A dedicated thermowell shall be provided for metering. Insertion length shall allow for a penetration to the center of the pipe after allowing for the length of the weld-o-let. Model Number 114CExxxxTAB3SCyyyBXW where xxxx = immersion length and yyyy = head length. Pipe Mounting Connection: Weld-O-Let Standard 3/4-14" NPT (with Female connector)

C. Installation

See DWG schematic of typical Chilled water meter set-up, provided.

Run a dedicated circuit (120VAC) to flow meter in EMT conduit. Leave slack in the wiring for connections (to be completed later). Provide a local disconnect (light switch) in order to allow for safe meter servicing. Run Liquid-Tight Flexible conduit from the flow meter to the transducers and RTD sensors. RTD wiring to be 4 conductor 20ga or better. Belden Number: 8484 (4 conductor copper) or better. Coaxial cable to be provided by GE with meter. Both RTD and coaxial may run in the same conduit if needed. Connect transducer w with transducer cable to the flow meter. GE onsite start-up will be included with purchase of meter – they will program and commission meter.

11. 338000 – CHILLED WATER UTILITIES

11.1 Chilled Water Information

Design Delta T should be 14-16 degrees across building.

There should be no requirement for secondary pumping of distribution system chilled water unless creating a recirculating loop within a building. Location of service relative to CUP and Plant delta P available will determine the pressure available to the building.

Differential pressure requirements at the building should be designed to not exceed 20 psi.

The Utility Chilled Water system begins at the CUP and ends at the building wall. After this point, refer to Division 23.

11.2 Chilled Water Design Issues

The designer is responsible for the selection of proper corrosion protection systems and building sealants for site soil conditions to address issues of conductivity, resistivity, acidity and water table elevation.

Chilled water systems on campus historically have been either welded steel pipe or ductile iron. HDPE has been used for temporary bypasses with success. It has not yet been used in a permanently installed system.

Summer setpoint for chilled water temperature delivered to the campus is 42 degrees F. As outdoor conditions enable a transition to non-refrigeration (thermocycle or “free”) cooling at the power plant the setpoint will move upward to a winter condition of 50 degrees F. More detail can be found in HVAC Division 23 of the MIT Design Standards.

The piping system design pressure is 150 psig. Typical system supply static pressure at the plant wall runs in the range of 90 to 130 psig.

Ductile Iron Pipe : Pipe shall conform to AWWA C151, minimum pressure class 250. All ductile iron pipes shall be cement mortar lined in conformance with AWWA C104 and shall have a 1 mil thick exterior petroleum asphaltic coating. Pipe shall be of domestic manufacture: U.S. Pipe, American Ductile Iron Pipe (American Pipe), or Atlantic States. No substitutions. Ductile iron chilled water piping joints are to be mechanically restrained. Where mechanically-restrained factory joints are not possible in design, Megalug joints are required.

Welded Steel Pipe:

All piping 10 inches and under shall be Schedule 40, all twelve inch and larger shall be .375" wall A53 ERW pipe. All piping shall be factory coated with an extruded polyethylene jacket by either Energy Coatings (PRITEC 10-60) or Shaw Coatings (Black Jacket). Fittings and weld joints shall be coated with RAYCHEM shrink sleeves or POLYKEN YGIII tape coating.

Valves shall conform to the latest revision of AWWA Standard C-515 covering Resilient Wedge Gate Valves for Water Supply Service. M&H C509 is an example. See www.mh-valve.com.

For ductile iron systems, provide for temporary restraints during hydrostatic testing if permanent restraints are not yet installed.

Thermally insulate above ground lines and surfaces including all system components including piping, valves, valve bonnets, flanges, strainers, fittings, expansion joints, special valves, control valves and cocks. See Detail M-1.

Refer to the following typical details for exterior wall piping penetration and pipe installation guidelines. See Detail M-5, M-6 and M-7.

Chilled water mass flow shall be measured using a flanged GE Panametrics Ultrasonic Flow Tube as the primary flow element combined with the DF868 energy meter. The flow element design will be conducted by GE directly, with the factory mandating the upstream and downstream straight pipe runs required to obtain the turn down ratios needed. Supply and Return pressure data will be processed through two Rosemount Model 3051 Gauge pressure transmitters that have been factory calibrated to a range of 0-150 PSIG. Transmitters will be coupled with 306 two-valve manifolds. Transmitter order number is: 3051TG2A2B21AS5B4Q4J3M5. Manifold order number is: 0306RT22AA11.

Supply and Return temperatures to be measured using a Rosemount Series 68 100 ohm platinum resistance temperature detector (RTD) sensor or approved substitute.

11.3 Chilled Water Quality Assurance

See 2.4 above.

11.4 Chilled Water Metering

A. General

1. Flow Measurement

Chilled water mass flow shall be measured using a flanged GE Panametrics Ultrasonic Flow Tube as the primary flow element combined with the DF868 energy meter. The flow meter system shall have a typical turndown ratio of at least 400:1. The flow element design will be handled by GE directly, with the factory mandating the upstream and downstream straight pipe runs required to obtain the turn down ratios needed.

2. Location of Spool Piece

The spool piece shall inserted into the supply line, before any building chilled water pumps or line branch take-offs. Installation in a horizontal run of pipe is preferred but if a vertical run is the only option this note will be passed on to GE for design review.

Pipe straight run requirements shall be as follows:

Upstream of the Flow Cell: Minimum of ten, preferably twenty pipe diameters

Downstream of the Flow Cell: Minimum of five, preferably ten pipe diameters

3. Temperature Measurement

Chilled water supply and return temperatures shall be measured using a Rosemount series 214 100 ohm platinum resistance temperature detector (RTD) sensor, or similar, installed in a thermowell. The thermowell locations shall be provided so as to record temperature of the supply and return service as they enter and exit the building. Each RTD will be wired directly to the DF868 energy meter to a supplied dual channel RTD input card.

4. Flow Output

The GE chilled water energy meter will have a Modbus RTU card supplied with the meter. This will be wired into a serial Modbus chain running between all respective energy meters in the project, terminating at the metering panel.

5. Pressure Measurement

Chilled water supply and return pressure shall be provided for managing building distribution. The PSI taps shall be installed in supply & return lines before any process take-offs. The two analog points will be wired into the two 4-20 mA analog inputs in the DF868 energy meter to a supplied dual channel 4-20mA input card.

6. Sensor Lines (Impulse Lines)

Sensor lines from the pressure taps to the Rosemount pressure transmitter shall be securely supported and guarded from accidental damage. All tubing, piping, fittings, valves, and other wetted parts of the sensing lines shall be 316 SS ½” tubing.

B. Products

1. Flow Element

A General Electric Flow Cell consisting of a flow tube of the diameter sized to capture the operational range of the Chilled water load for the building. GE configurations sheets shall be filled out for sizing the flow tubes. The flow tube shall be fitted with raised ANSI 150# flanges. The contractor shall install flanges in the existing metering loop to accommodate the metering tube. All associated coaxial cable will also be provided in sufficient length to connect the flow element to the DF868 energy meter, not more than 100 cable feet distant.

2. Pressure Transmitters

Two Rosemount Model 3051 Gauge pressure transmitters shall be provided. Transmitter shall be factory calibrated to a range of 0 to 150 PSIG. Transmitter will be coupled with a 306 two-valve manifold and installed in such a way that the valve handles and calibration port are easily accessible. A ¼ turn ball valve shall be used for the root isolation valve as well as a blowdown valve.

Transmitter mfg. order number: 3051TG2A2B21AS5B4Q4J3M5

Manifold mfg. order number: 0306RT22AA11

3. Temperature Sensors, Thermowells and Temperature Transmitters

a. Temperature Sensor

Two Rosemount Series 214 RTD Platinum Thin Film Temperature Sensors with thermowells – one in the chill water supply line and one in the chill water return line.

Model No. 214CRTSMB1S4ExxxxSLAT1C3B1G3FAEyyyXW where xxxx = sensor length (Immersion length + head length) and yyy = extension length.

Sensor lead termination shall consist of a painted aluminum connection head with flat cover containing six (6) terminals. Adapter shall be spring loaded-type.

b. Thermowell

A dedicated thermowell shall be provided for metering. Insertion length shall allow for a penetration to the center of the pipe after allowing for the length of the weld-o-let. Model Number 114CExxxxTAB3SCyyyBXW where xxxx = immersion length and yyyy = head length. Pipe Mounting Connection: Weld-O-Let Standard 3/4-14" NPT (with Female connector)

C. Installation

See DWG schematic of typical Chilled water meter set-up, provided.
Run a dedicated circuit (120VAC) to flow meter in EMT conduit. Leave slack in the wiring for connections (to be completed later). Provide a local disconnect (light switch) in order to allow for safe meter servicing. Run Liquid –Tight Flexible conduit from the flow meter to the transducers and RTD sensors. RTD wiring to be 4 conductor 20ga or better. Belden Number: 8484 (4 conductor copper) or better. Coaxial cable to be provided by GE with meter. Both RTD and coaxial may run in the same conduit if needed. Connect transducer w with transducer cable to the flow meter. GE onsite start-up will be included with purchase of meter – they will program and commission meter.

12. 339000 – NATURAL GAS UTILITIES

12.1 Natural Gas Information

The natural gas provider for the campus is Eversource.

MIT has several segments of a buried gas system.

The gas company is to be provided in writing the total connected load for new services.

The MIT Natural Gas System begins at the Eversource meter and ends at the first isolation valve.

12.2 Natural Gas Design Issues

The designer must review the preliminary gas system design with the gas provider early in the design process and regularly thereafter.

The gas company will make the connections to the gas main and will provide the service branch to the building. MIT may be back-charged for this expense.

The gas company is to be provided in writing the total connected load for new gas consumption.

The gas company typically furnishes and installs the gas meter.

Provide swing joints at buildings at buildings as required by codes and standards to account for building settlement.

Refer to the Plumbing sections of the MIT Design Standards for laboratory gas requirements.

MIT requires additional metering of natural gas flow to be remotely monitored.

12.3 Natural Gas Quality Assurance

See 2.4 above.

APPENDIX A: SANITARY SEWER OVERVIEW

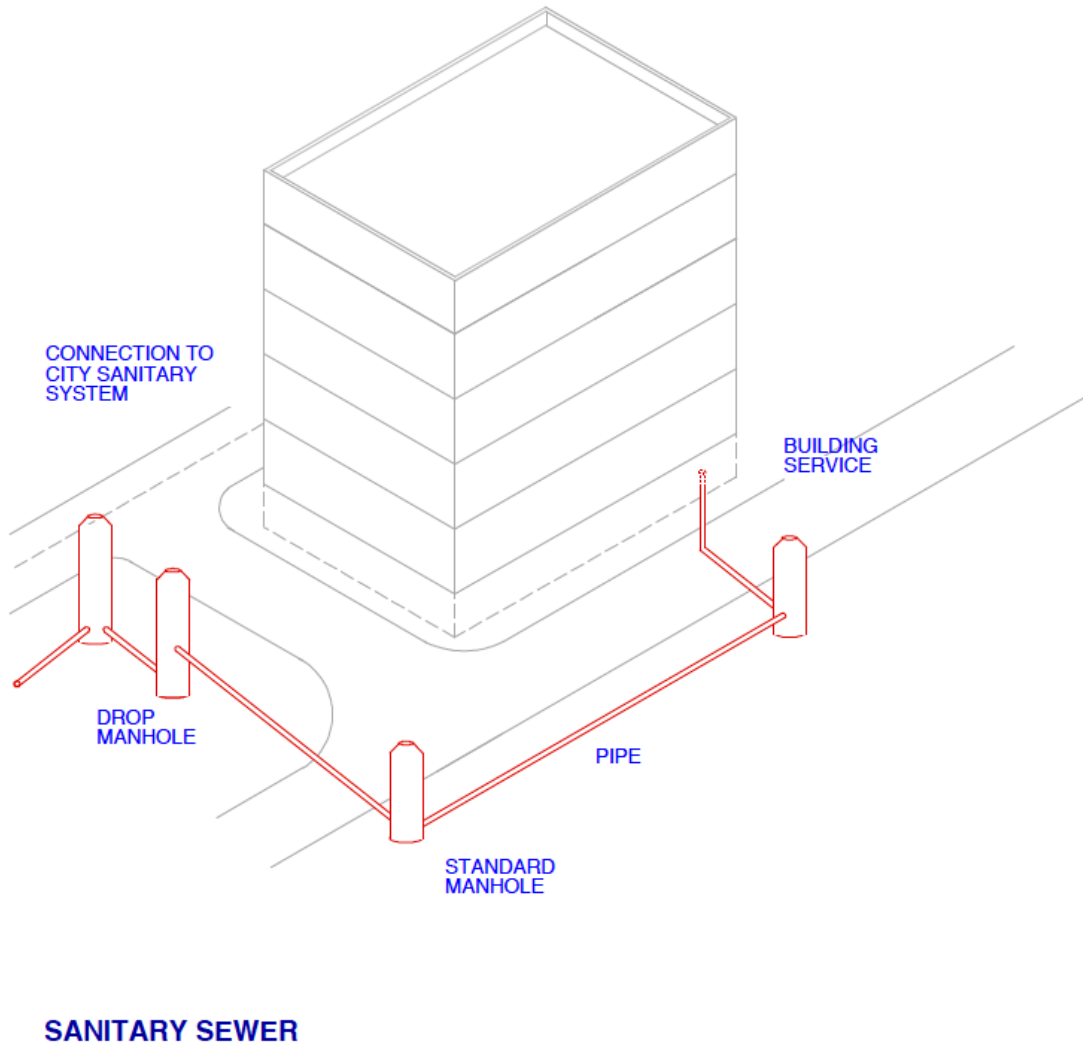

APPENDIX B: STORMWATER OVERVIEW

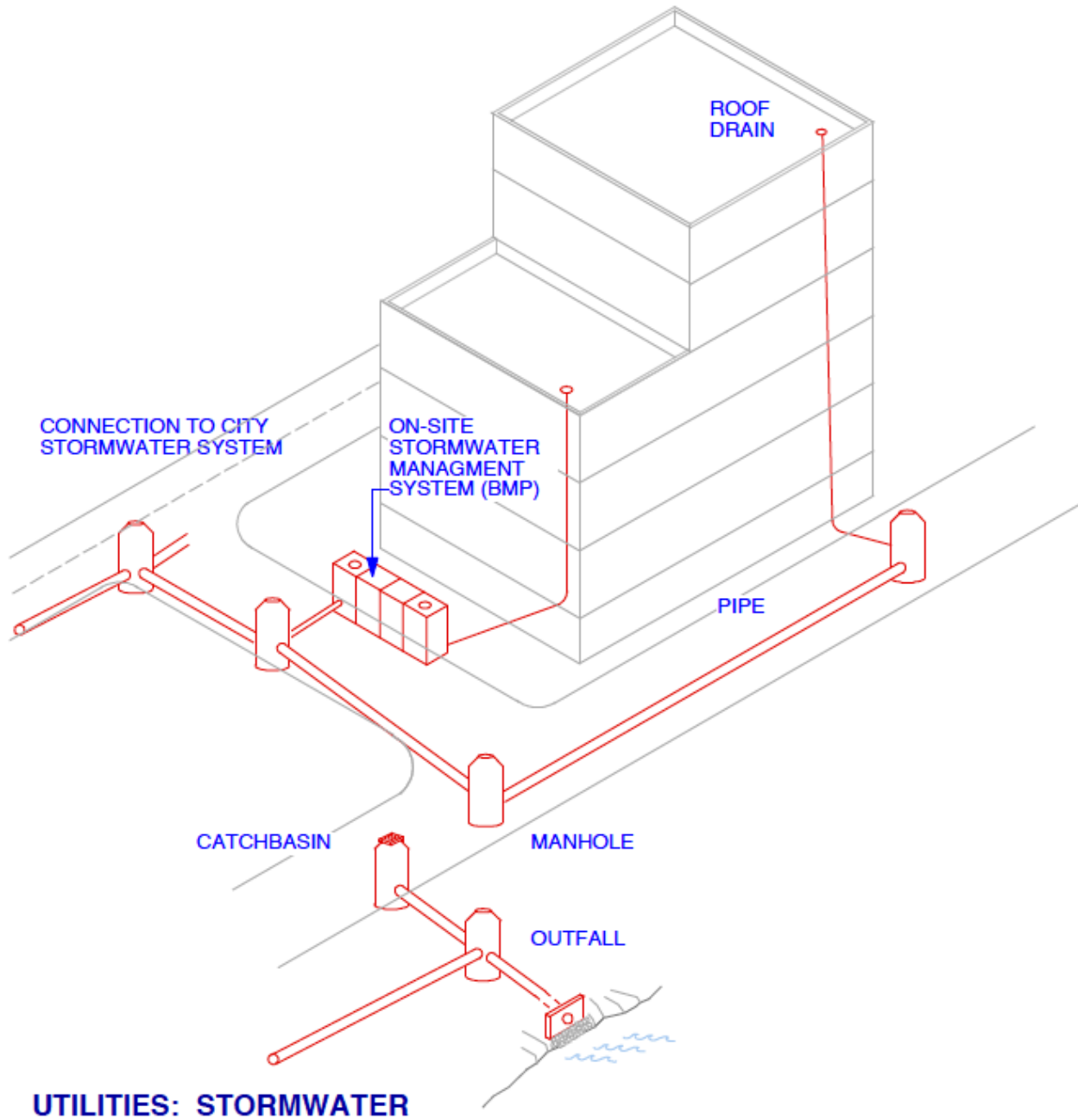

APPENDIX C: BUILDING ENTRANCES

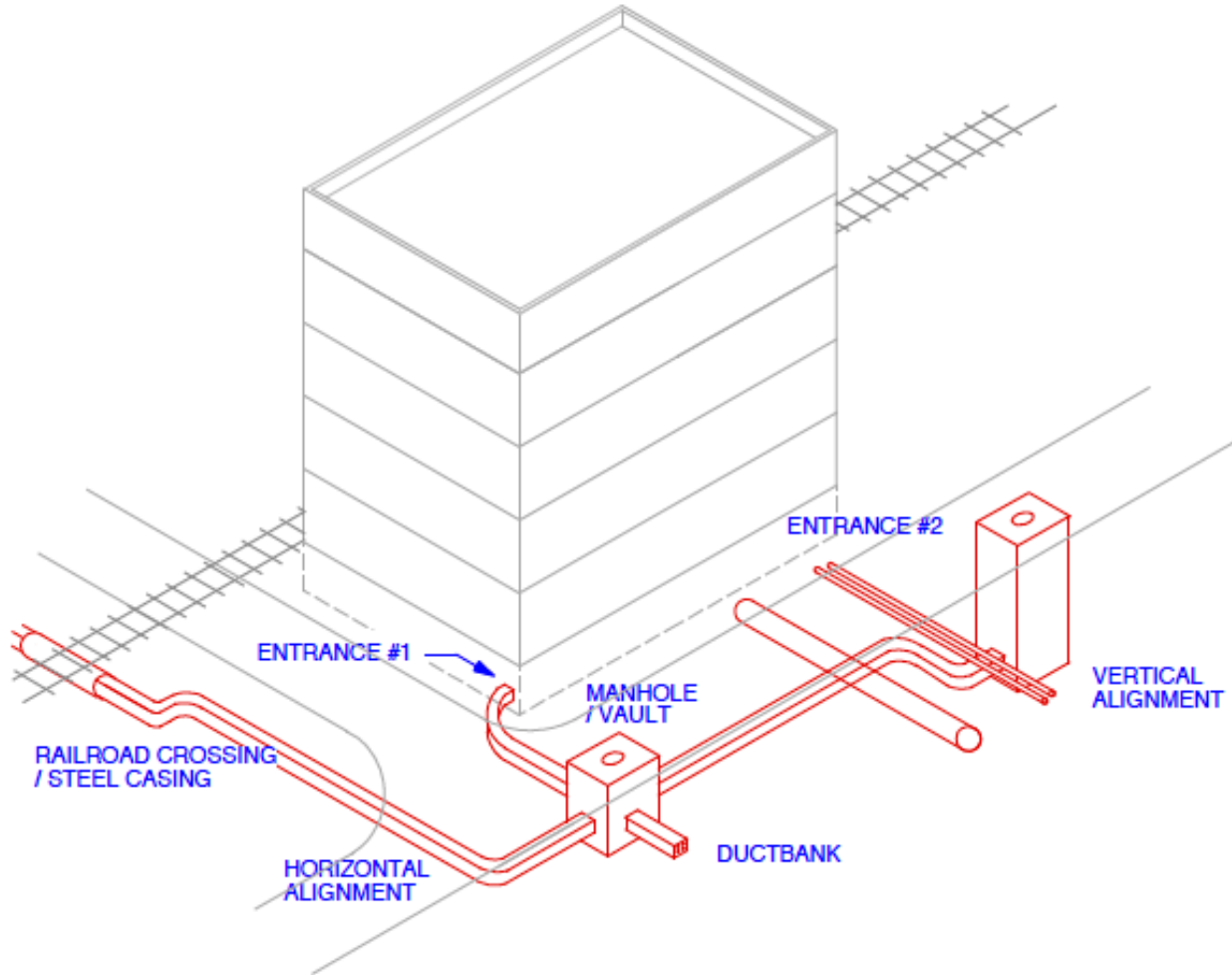

APPENDIX D: UTILITIES DETAILS

C1 - Typical Pipe Bedding Detail
C2 - Precast Concrete Catch Basin
C3 - Precast Concrete Drain Manhole
C4 - Typical Ductbank
C5 - Typical Electrical/Telecom Manhole
C5A - Typical Electrical/Telecom Rack Detail
C6 - Typical Electrical/Telecom Manhole Cover and Frame
C7 - Water Service
C8 - Hydrant and Valve
C9 - Tapping Sleeve and Valve
C10 - Blow-Off Hydrant
C11 - Post Indicator Valve
C12 - Typical Sanitary Sewer Manhole
C13 - Inside Drop Manhole (Plan)
C13A - Inside Drop Manhole Elevation

M1 - Steam and Condensate Piping in Manhole - Insulation Installation Detail
M2 - Exterior Above Ground Insulation Installation Detail
M3 - Typical Pipe Details
M4 - Valve Box Cover
M5 - Pipe Hanger Support
M6 - Single Pipe Support
M7 - Multiple Pipe Support
M8 - Standard Anchor Assembly
M9 - Not used
M10 - Not used
M11 - Dirt Leg and Steam Trap Detail, Low and Medium Pressure - Bldg Return
M12 - Cross Section of Engineered Pipe - Steam Supply and Condensate Return
M13 - Gland Seal Assembly
M14 - Wall Penetration for Underground Mechanical Services
M15 - Hot Pipe Penetration Detail
M16 - Not used
M17 - Condensate End Seal Assembly
M18 - High Pressure Condensate Return Sparger

MH1 - Typical Manhole Layout Elevation - Steam
MH2 - Not used
MH3 - Typical Manhole Trap Assembly Detail – High Pressure Steam Manholes
MH4 - Typical Manhole Vent Detail
MH5 - Typical Manhole Layout - Plan - Steam
MH6 - Typical Manhole Pumping Detail

END OF DOCUMENT

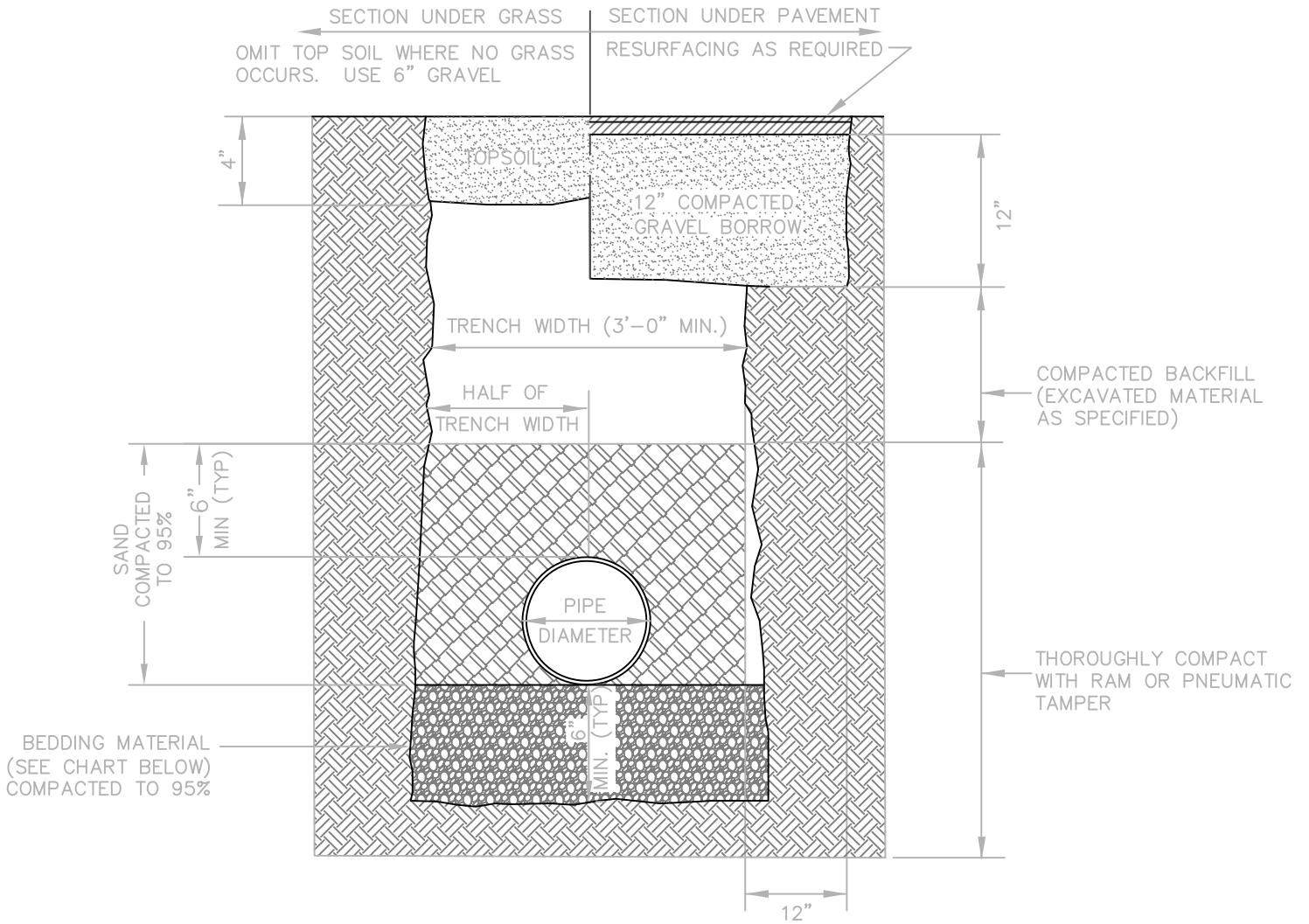

UTILITY	BEDDING MATERIAL
STEAM/CONDENSATE	SAND
HOT WATER	SAND
CHILLED WATER	CRUSHED STONE
DOMESTIC WATER	SAND OR CRUSHED STONE
FIRE PROTECTION	SAND
STORM DRAIN	SCREENED GRAVEL OR CRUSHED STONE
SANITARY SEWER	SAND OR CRUSHED STONE

TYPICAL PIPE BEDDING DETAIL

NTS

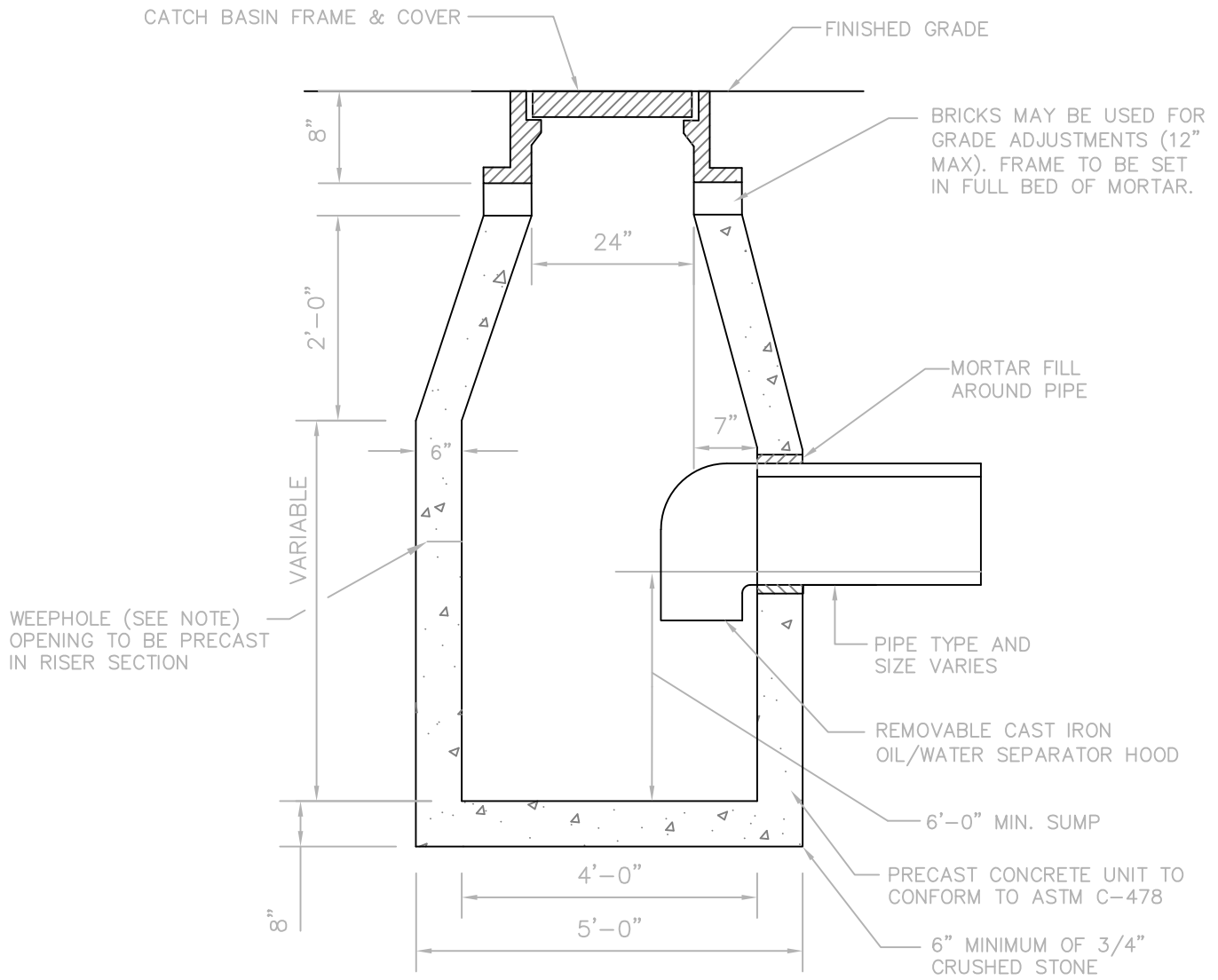

NOTE:
 WEEPHOLES SHALL NOT BE PROVIDED IN AREAS OF
 CONTAMINATION OR HIGH GROUNDWATER.

PRECAST CONCRETE CATCH BASIN

NTS

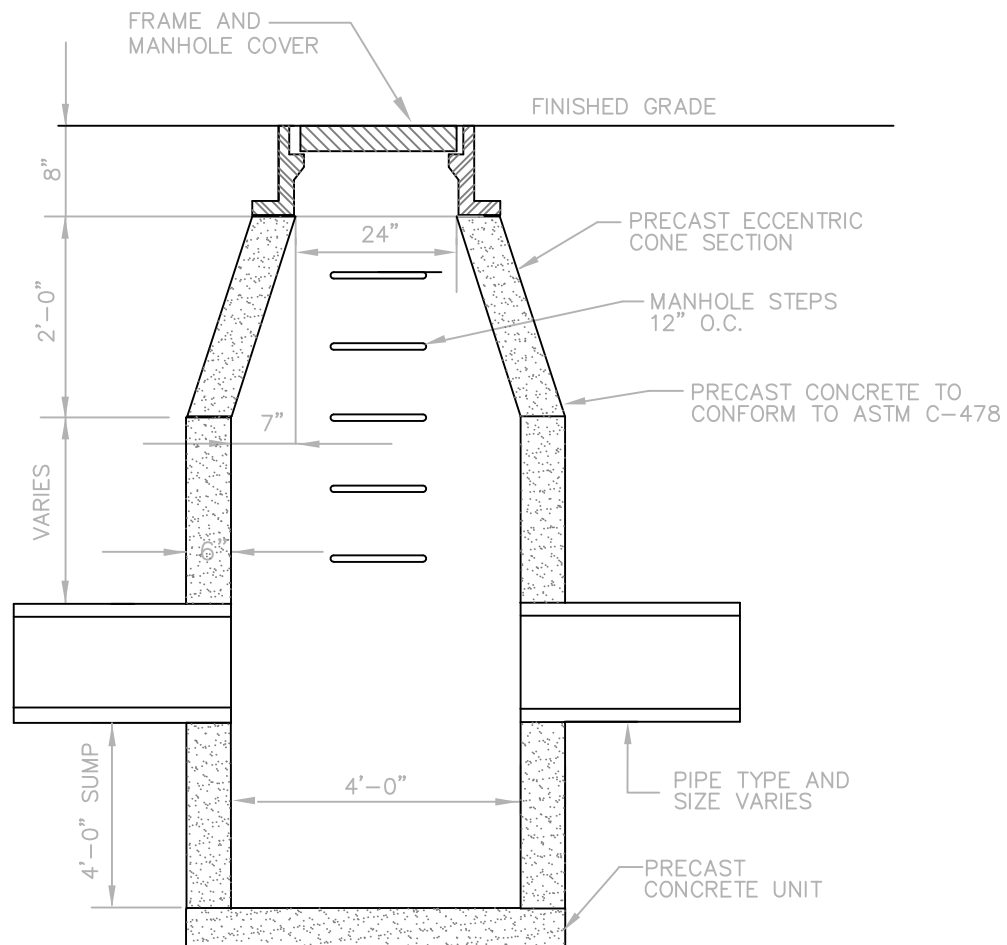

PRECAST CONCRETE DRAIN MANHOLE

NTS

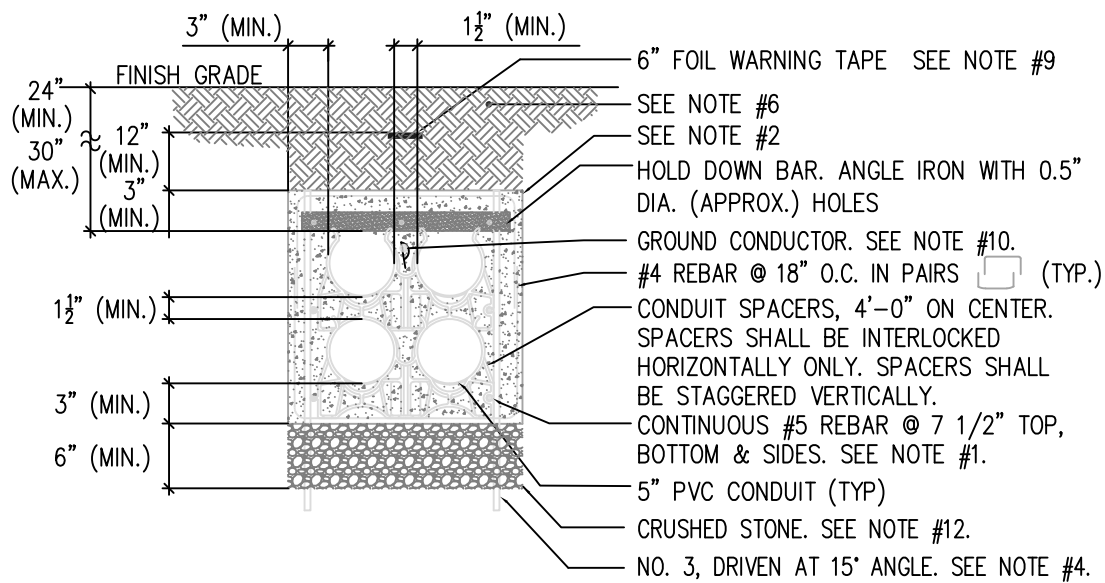

NOTES:

1. DUCT BANK SHALL BE ENCASED IN CONCRETE WITH A LEAST 3" OF CONCRETE AT TOP, BOTTOM AND SIDES. THIS IS A TYPICAL EXAMPLE OF DUCT BANK CONSTRUCTION. FOR ADDITIONAL COLUMN AND/OR ROW OF CONDUIT PROVIDE AN ADDITIONAL #5 REBAR SPACED AS NOTED ABOVE.
2. THE CONCRETE SHALL INCORPORATE 3/8" AGGREGATE WITH A NOMINAL COMPRESSIVE STRENGTH OF 2,500 LBS. PER SQUARE INCH. THE SLUMP SHALL BE AT UPPER END OF RANGE, PREFERABLY 7 TO 8 INCHES. IT SHOULD HAVE JUST ENOUGH SLUMP TO FLOW TO BOTTOM OF DUCT BANK AND YET NOT BE SO WET AS TO CAUSE CONDUITS TO FLOAT EXCESSIVELY. COORDINATE EXACT REQUIREMENTS WITH CIVIL ENGINEER. AN INTERNAL CONCRETE VIBRATOR SHALL BE USED TO REMOVE AIR BUBBLES FROM CONCRETE.
3. WHEN PLACING CONCRETE AROUND CONDUITS ADJUST DELIVERY CHUTE SO FALL OF CONCRETE INTO TRENCH IS MINIMAL. POUR CONCRETE SLOWLY AND DISTRIBUTE IT EVENLY SO AS NOT TO DISLodge THE SPACERS.
4. THE REBAR STAKES AND HOLD DOWN BARS ARE REQUIRED TO PREVENT FLOTATION OF DUCT BANK. FLOTATION IS CAUSED BY DUCT BUOYANCY AND CHURNING OF CONCRETE DURING POUR. FOUR SETS OF REBAR STAKES AND HOLD DOWN BARS SHOULD BE USED PER 20 FEET OF DUCT BANK. THE 3" EXTENSION OF REBAR ABOVE DUCTS IS TO BE USED AS A CONCRETE GAUGE.
5. CONCRETE ENVELOPE SHALL BE POURED IN FORM. DO NOT USE SIDES OF TRENCH TO FORM VERTICAL WALLS, UNLESS APPROVED BY ENGINEER.
6. BACKFILL DUCTS WITH SELECT FILL. BACKFILL TRENCH BANK IN LAYERS AFTER CONCRETE HAS SET.
7. STEEL REINFORCING RODS SHALL BE INTERFACED WITH BUILDING FOUNDATION AND MANHOLE WALLS TO MINIMIZE SHEARING.
8. CONCRETE CONSTRUCTION JOINTS SHALL NOT BE SPACED LESS THAN 40 FEET O.C.
9. FOIL WARNING TAPE SHALL BE TERRA-TAPE "SENTRYLINE DETECTABLE" 6" WIDE OR APPROVED EQUAL. COLOR CODE SHALL BE AS FOLLOWS; RED-ELECTRIC, ORANGE-COMMUNICATIONS. IMPRINTED TEXT SHALL IDENTIFY DUCT BANK SERVICE.
10. REQUIRED FOR SERVICE ENTRANCE DUCTBANK ONLY. REFER TO BUILDING GROUNDING ELECTRODE DETAIL.
11. PROVIDE PULL STRING IN SPARE CONDUITS.
12. WRAP CRUSHED STONE IN GEOTEXTILE FABRIC. COMPACT CRUSHED STONE WITH A MINIMUM OF FOUR PASSES WITH A VIBRATION PLATE COMPACTOR.
13. IF ELECTRIC AND TELECOM CONDUITS ARE ROUTED IN THE SAME POUR, A MINIMUM OF 6" SHALL BE MAINTAINED BETWEEN CONDUITS EDGES OF THE TWO SYSTEMS.

TYPICAL DUCTBANK

NTS

MIT Department of
FACILITIES

77 Massachusetts Avenue, Cambridge, MA 02139

C4

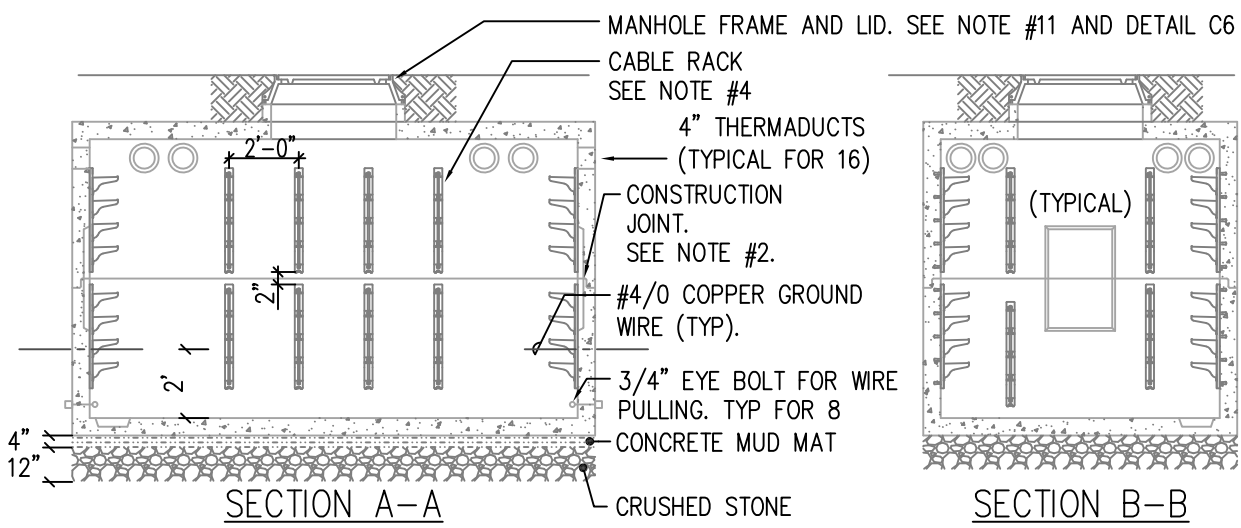
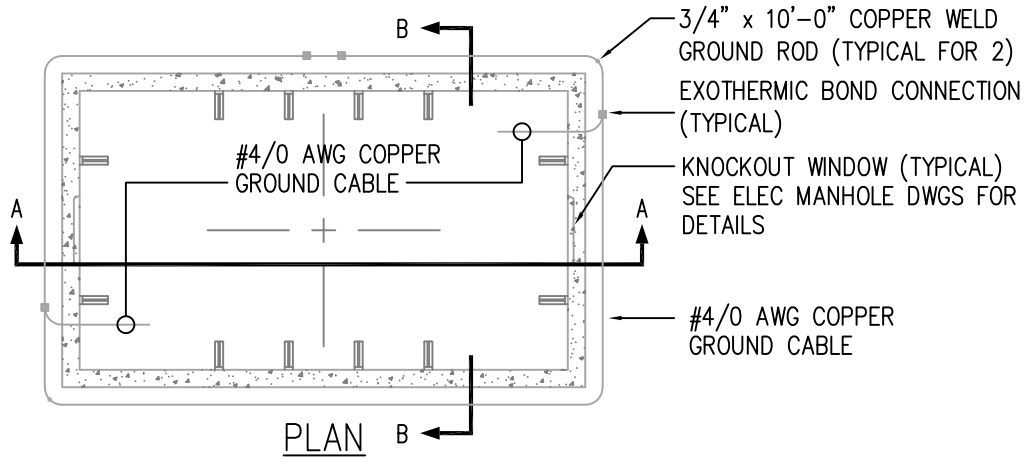

MANHOLE DIMENSIONS:

6'-0" (MIN.) x 9'-0" (MIN) x 8'-0" DEEP, PER ELECTRICAL DRAWINGS

NOTES:

1. CONCRETE MINIMUM STRENGTH - 5,000 PSI @ 28 DAYS. MANHOLE SHALL BE CAPABLE OF SUPPORTING H2O LOADING.
2. CONSTRUCTION JOINT SHALL BE SEALED WITH 1" BUTYL RUBBER SEALANT, CONSEAL #CS#101 OR EQUAL.
3. EXTERIOR WALL SURFACES OF MANHOLE SHALL BE DAMP PROOFED WITH EMULSIFIED ASPHALT COMPOUND, SONNEBORN HYDROCID #700B OR EQUAL.
4. 8" LONG NONMETALLIC ARM. SEE MANHOLE CABLE RACK DETAIL C5A.
5. PROVIDE SUMP PIT IN ONE CORNER OF MANHOLE: 1'-0" x 1'-0" x 6" DEEP. SLOPE FLOOR 1/4" PER FOOT TOWARD SUMP.
6. PROVIDE PULLING IRONS ABOVE AND BELOW ALL WINDOWS.
7. PROVIDE FIBERGLASS CABLE RACKS WITH STAINLESS STEEL HARDWARE.
8. DO NOT PROVIDE LADDERS, GROUND RODS, OR GROUND MATS INSIDE MANHOLES.
9. GROUND CABLES SHALL BE BROUGHT OUT HIGH IN MANHOLES TO GROUND ROD(S) OUTSIDE MANHOLE.
10. DUCTBANK SEAM SHALL BE GROUTED AT MANHOLE WINDOW.
11. PROVIDE BRICK COURSES TO RAISE FRAME AND COVER TO GRADE. INSIDE SURFACE OF BRICK SHALL BE PARGED. EXTERIOR SURFACE SHALL BE COVERED WITH MORTAR.

TYPICAL ELECTRICAL/TELECOM MANHOLE

NTS

C5

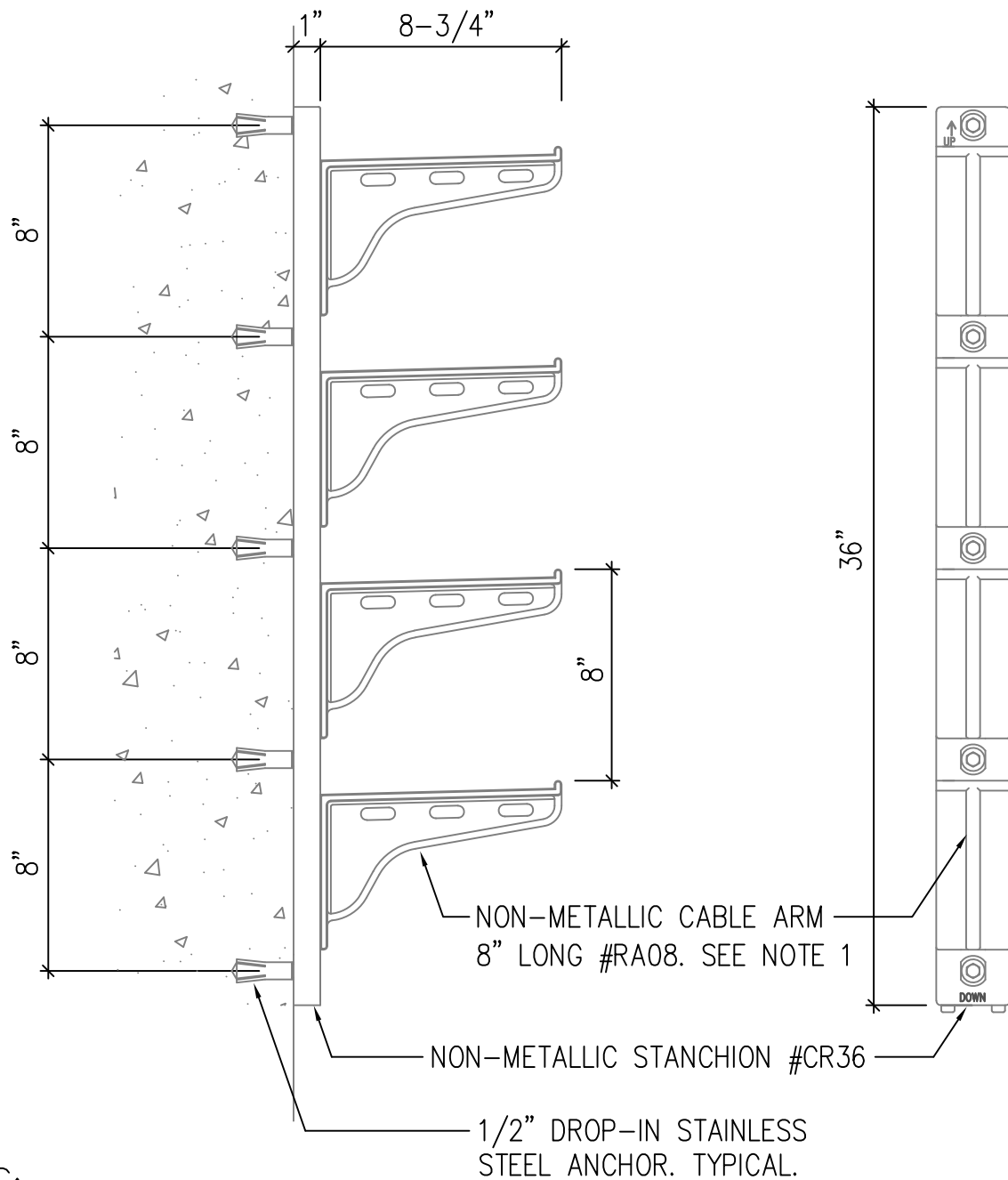

NOTES:

1. NON-METALLIC CABLE RACK COMPONENTS SHALL BE UNDERGROUND MATERIALS "TYPE B" OR APPROVED EQUAL. ALL METAL HARDWARE SHALL BE STAINLESS STEEL.
2. SEE MANHOLE DETAIL C5. PROVIDE CABLE ARMS AS REQUIRED.

TYPICAL ELECTRICAL/TELECOM MANHOLE RACK DETAIL

NTS

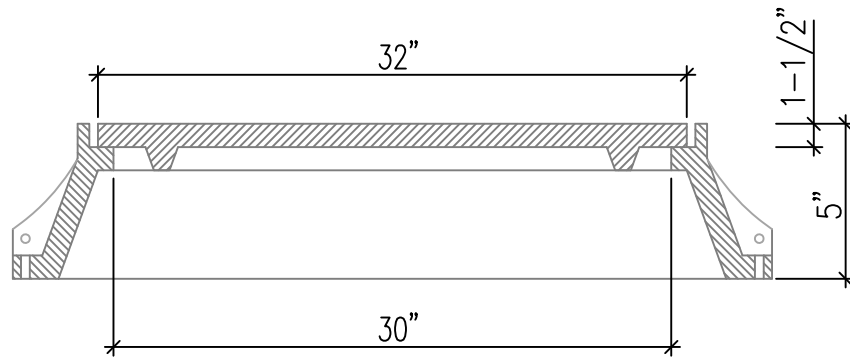

SECTION A-A

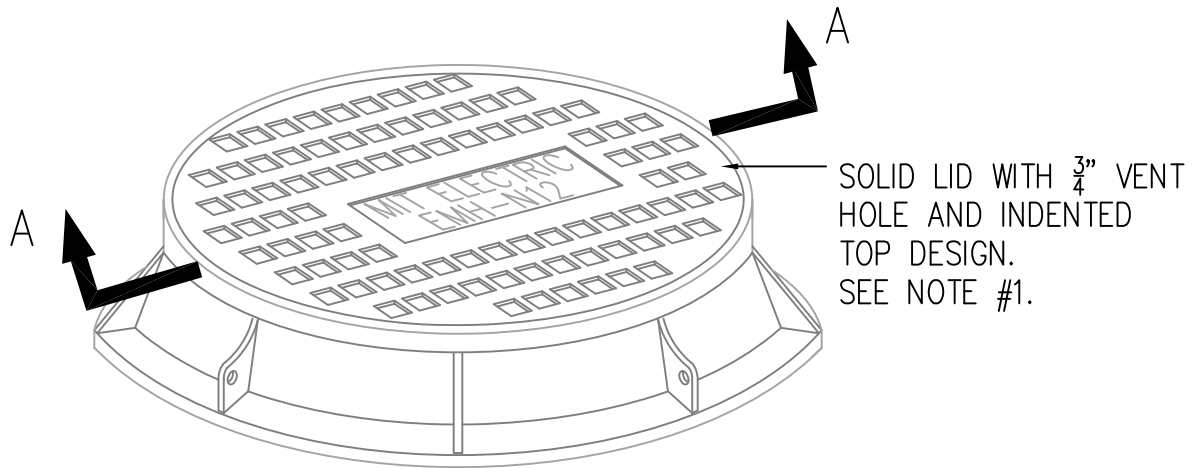

SOLID LID WITH $\frac{3}{4}$ " VENT HOLE AND INDENTED TOP DESIGN. SEE NOTE #1.

PERSPECTIVE

NOTES:

1. MANHOLE FRAMES AND COVERS SHALL BE EJ SERIES 3200 LOCKING COMPOSITE ASSEMBLY AS CUSTOMIZED FOR MIT. PROVIDE TWO QUARTER-TURN LOCKS WITH SECURITY BOLT.
2. COVER TO BE LETTERED "MIT ELECTRIC EMH-XXX" OR "MIT TELECOM TMH-XXX", REFER TO RESPECTIVE MANHOLE DETAIL FOR 'XXX' DESIGNATION.
3. COVER SHALL BE AT LEAST 32" DIAMETER. MIT UTILITIES APPROVAL REQUIRED FOR SMALLER DIAMETER
4. COMPOSITE ASSEMBLIES SHALL NOT BE USED ON CITY OF CAMBRIDGE STREETS OR DCR PARKS AND ROADWAYS. CONTACT RESPECTIVE ENTITY FOR CURRENT STANDARDS.

**TYPICAL ELECTRICAL/TELECOM MANHOLE
COVER AND FRAME**

NTS

MIT Department of
FACILITIES

77 Massachusetts Avenue, Cambridge, MA 02139

C6

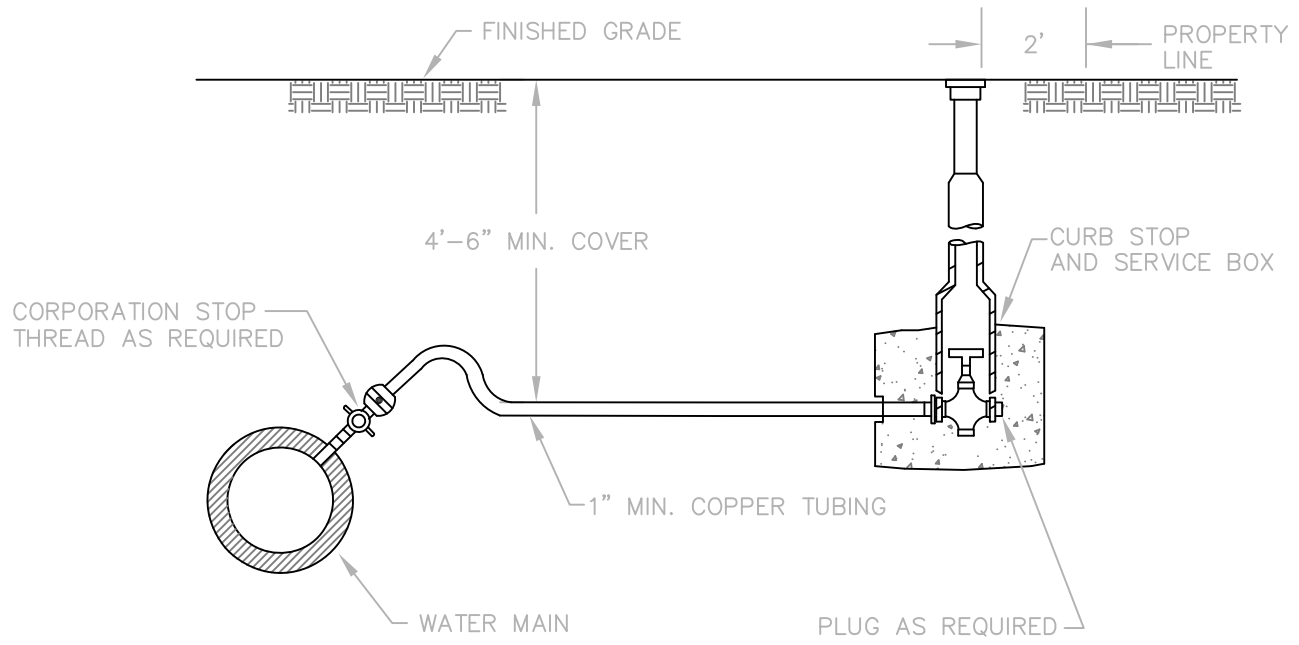

WATER SERVICE

NTS

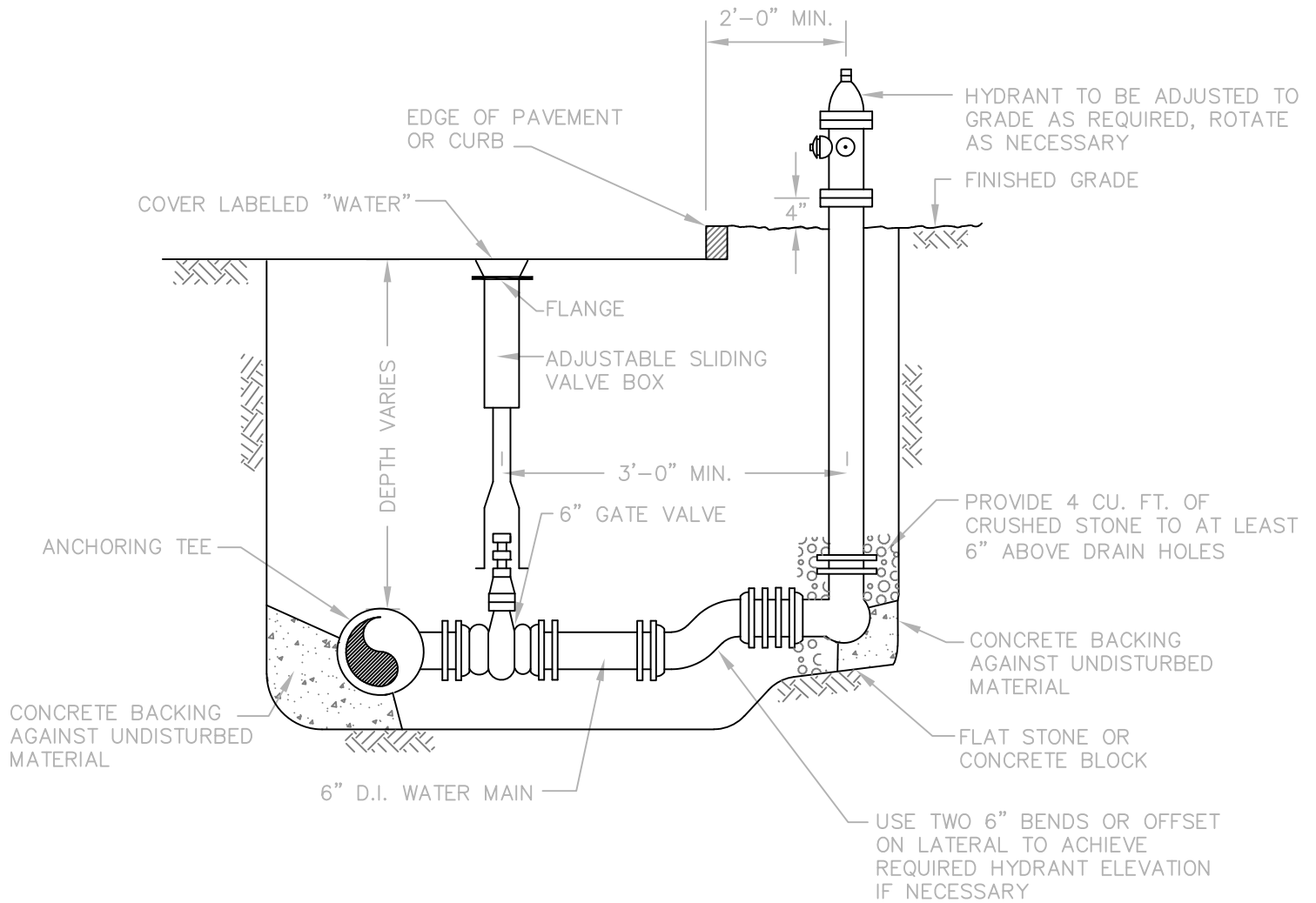

HYDRANT AND VALVE

NTS

MIT Department of
FACILITIES

77 Massachusetts Avenue, Cambridge, MA 02139

C8

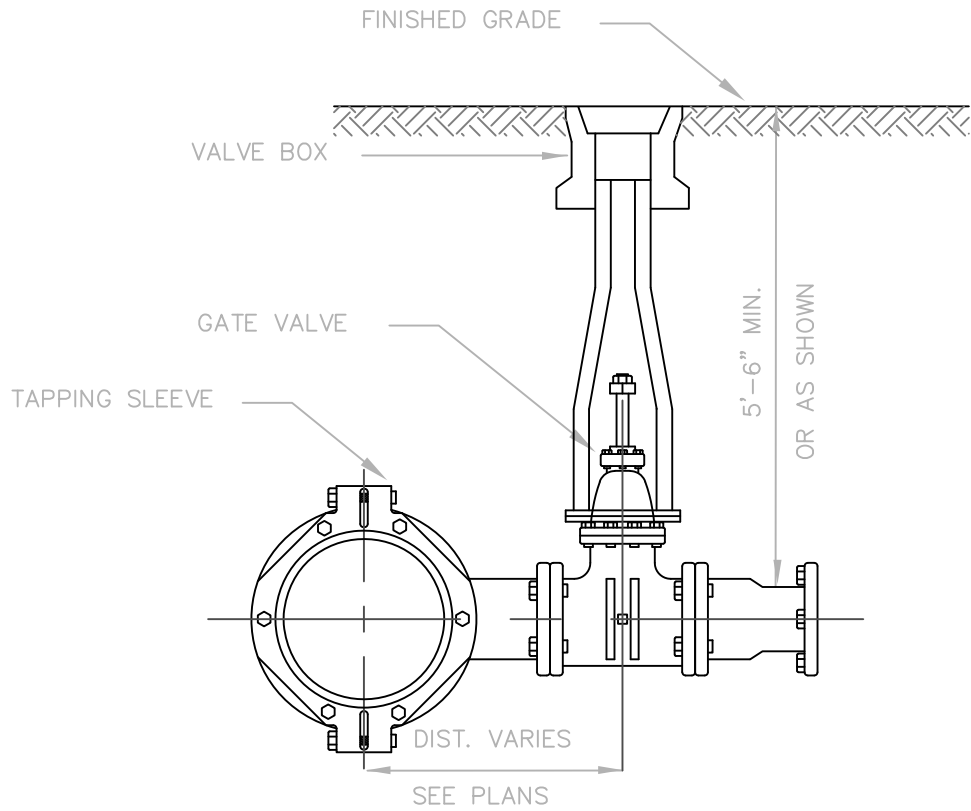

TAPPING SLEEVE AND VALVE

NTS

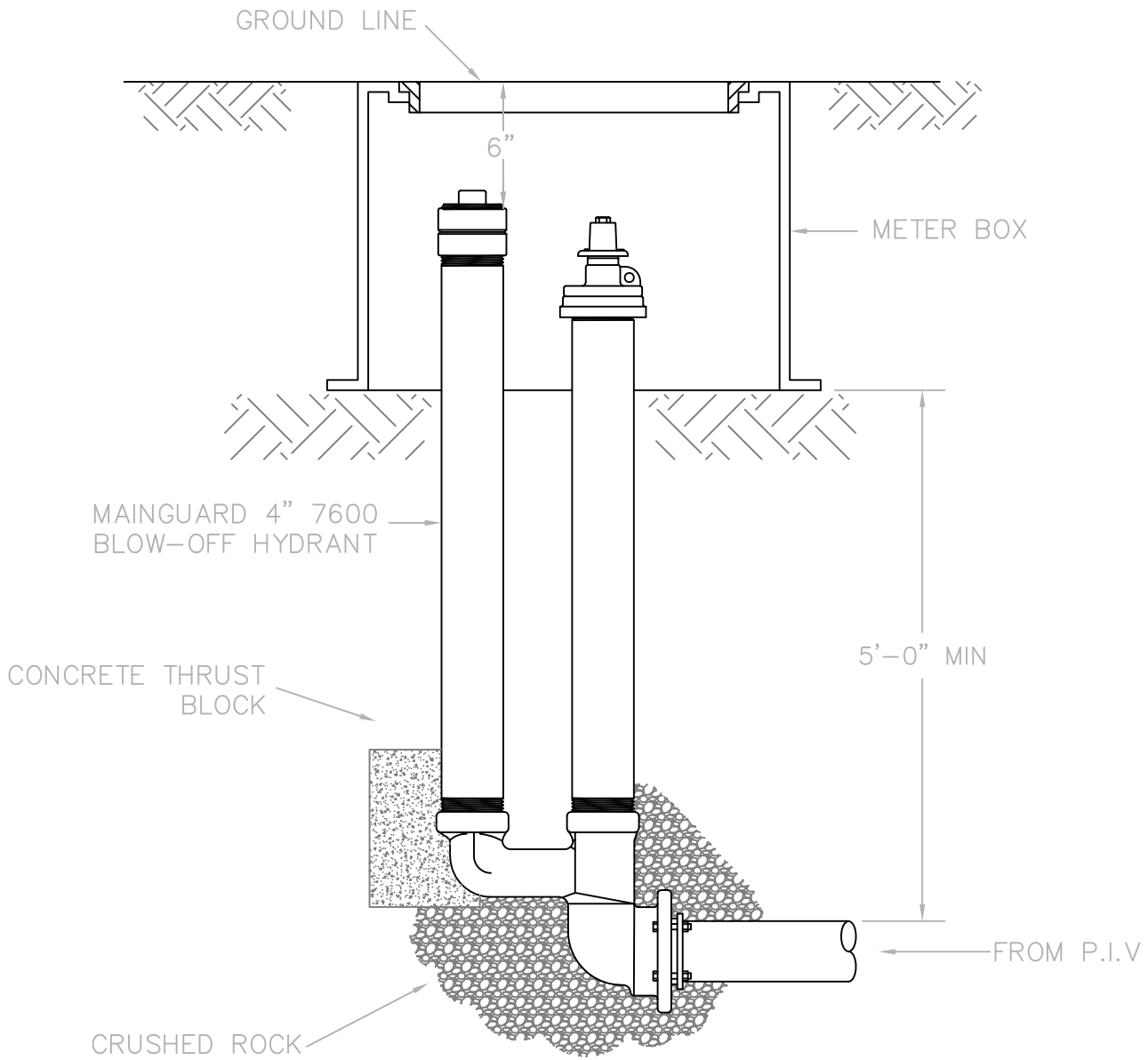

BLOW-OFF HYDRANT

NTS

MIT Department of
FACILITIES

77 Massachusetts Avenue, Cambridge, MA 02139

C10

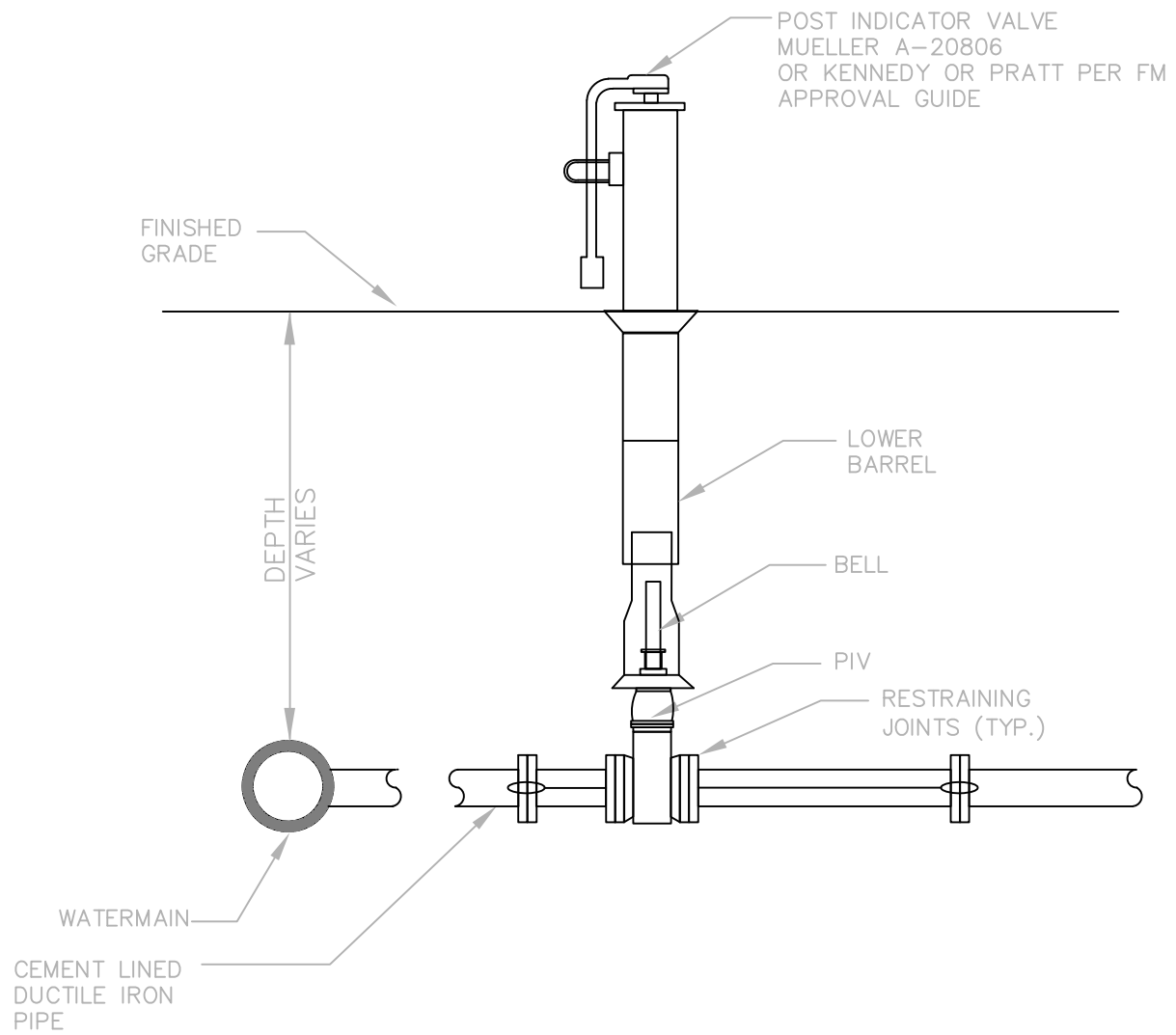

POST INDICATOR VALVE

NTS

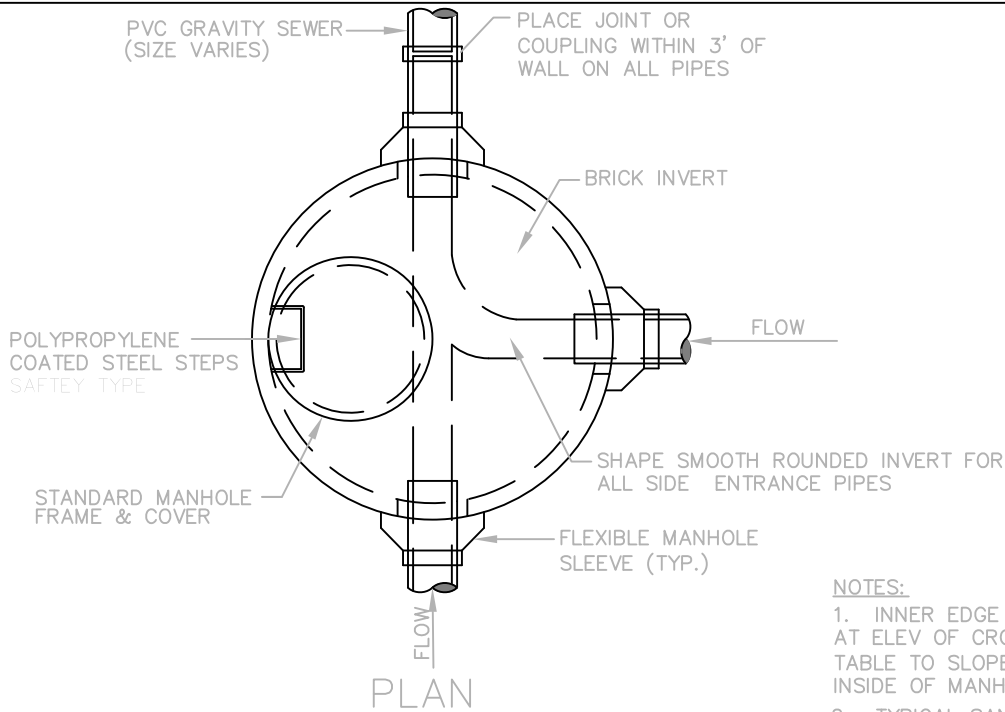

NOTES:

- 1. INNER EDGE OF BRICK TABLE TO BE AT ELEV. OF CROWN OF TOP OF PIPE. TABLE TO SLOPE AT 1" PER 1' TO INSIDE OF MANHOLE BASE
- 2. TYPICAL SANITARY MANHOLE TO BE 4 FT. DIA.

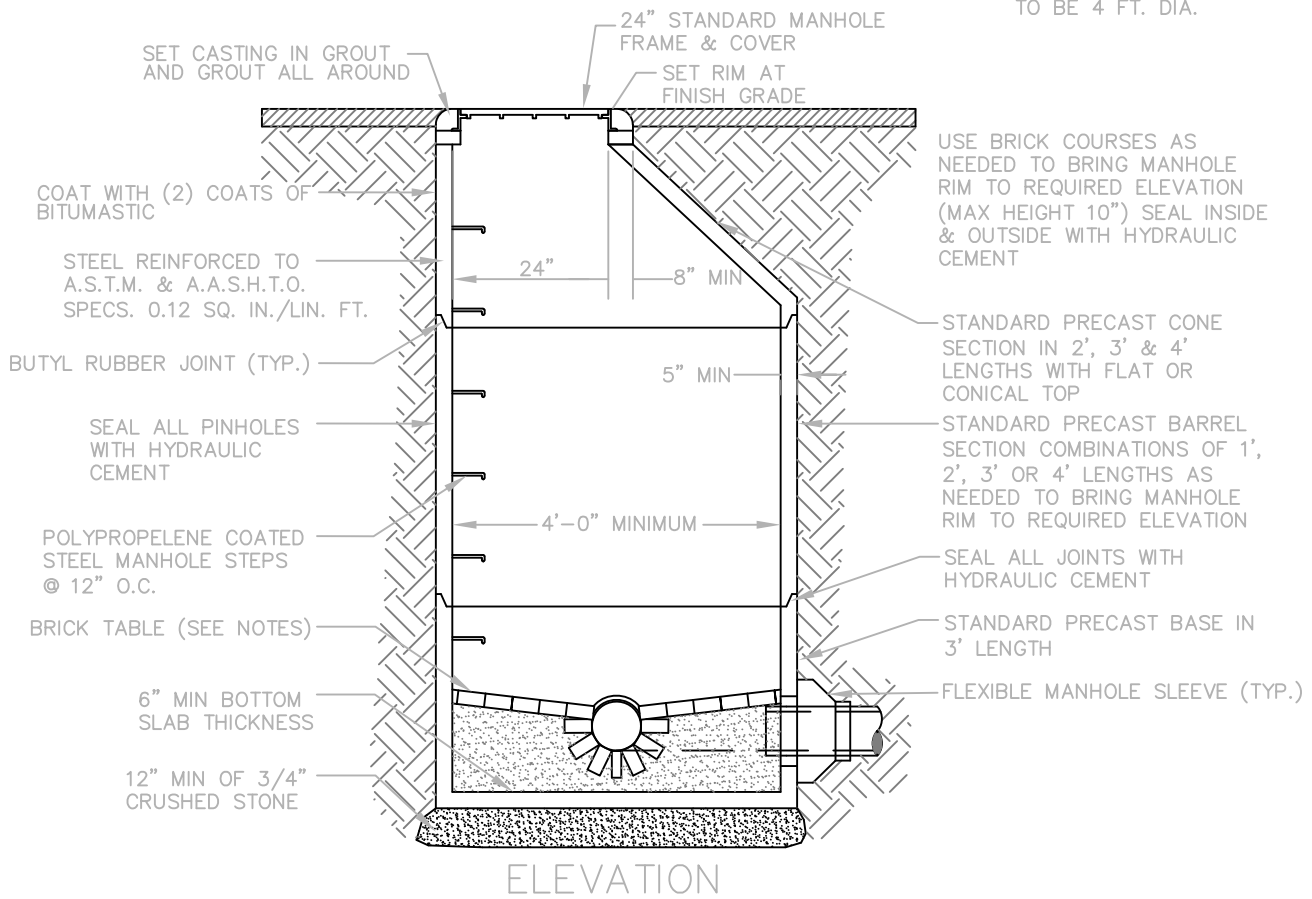

TYPICAL SANITARY SEWER MANHOLE

NTS

PVC GRAVITY SEWER
(SIZE VARIES) (TYP.)

PLACE JOINT OR
COUPLING WITHIN 3'
OF
WALL ON ALL PIPES

BRICK INVERT

INSIDE DROP CONNECTION
STRAPPED TO MH WALL.

POLYPROPYLENE COATED STEEL
MANHOLE STEPS SAFETY
TYPE

WYE BRANCH

STANDARD MANHOLE
FRAME & COVER

SHAPE SMOOTH ROUNDED
INVERT FOR ALL SIDE
ENTRANCE PIPES

FLEXIBLE MANHOLE
SLEEVE (TYP.)

FLOW

FLOW

INSIDE DROP MANHOLE (PLAN)

NTS

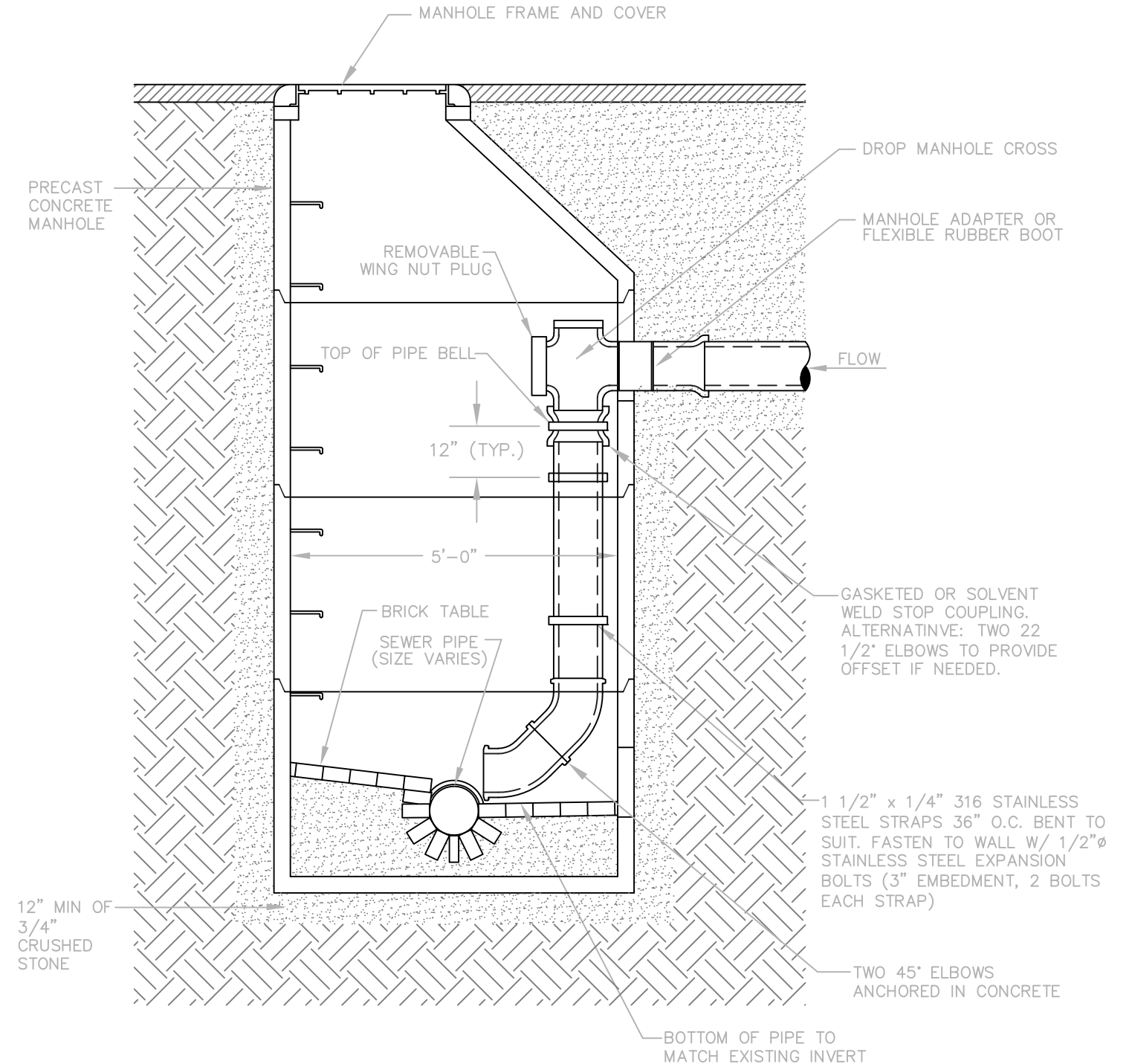

NOTES:

1. DROP MANHOLES SHALL BE USED WHEN ENTRANCE PIPE INVERTS ARE 2' OR GREATER THAN MANHOLE INVERT.

**INSIDE DROP MANHOLE
ELEVATION**

NTS

MIT Department of
FACILITIES

77 Massachusetts Avenue, Cambridge, MA 02139

C13A

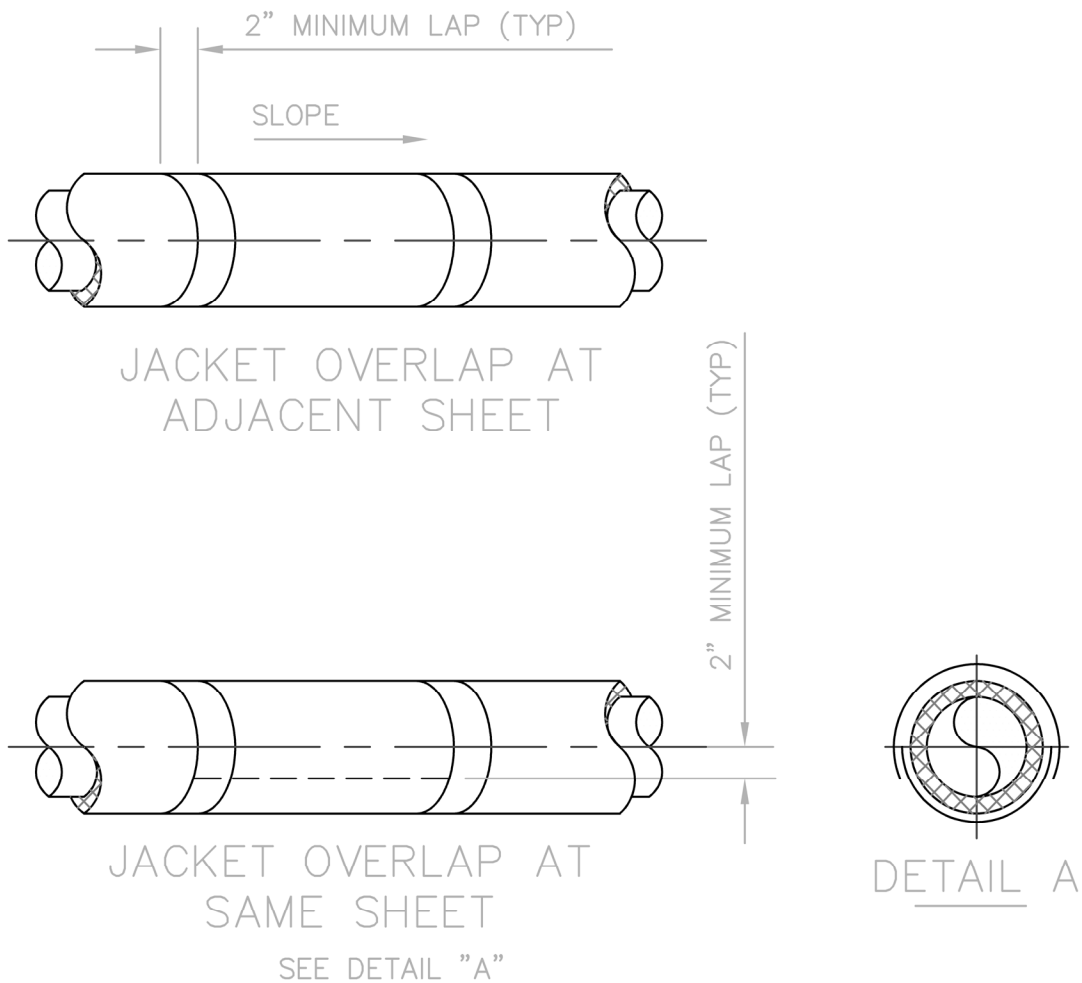

NOTES:

1. INSULATING MATERIAL FOR STEAM AND CONDENSATE PIPING SHALL BE JACKETED PYROGEL, EXCEPT AT HANGERS. REFER TO MIT DESIGN STANDARDS DIVISION 33, SECTION 9.4 FOR JACKET REQUIREMENTS.
2. AT HANGERS USE HYDROUS CALCIUM SILICATE PIPE INSULATION: THERMO-12/GOLD MEETING ASTM C 533, TYPE1; RIGID MOLDED PIPE; ASBESTOS-FREE COLOR CODED THROUGHOUT MATERIAL THICKNESS. COMPRESSIVE STRENGTH: MINIMUM OF 100 PSI.
3. TIE WIRE: 16 GAGE (0.045mm) STAINLESS STEEL WITH TWISTED ENDS ON MAXIMUM 12 INCH (300mm) CENTERS.

**STEAM AND CONDENSATE PIPING IN MANHOLE
INSULATION INSTALLATION DETAIL**

NTS

MIT Department of
FACILITIES

77 Massachusetts Avenue, Cambridge, MA 02139

M1

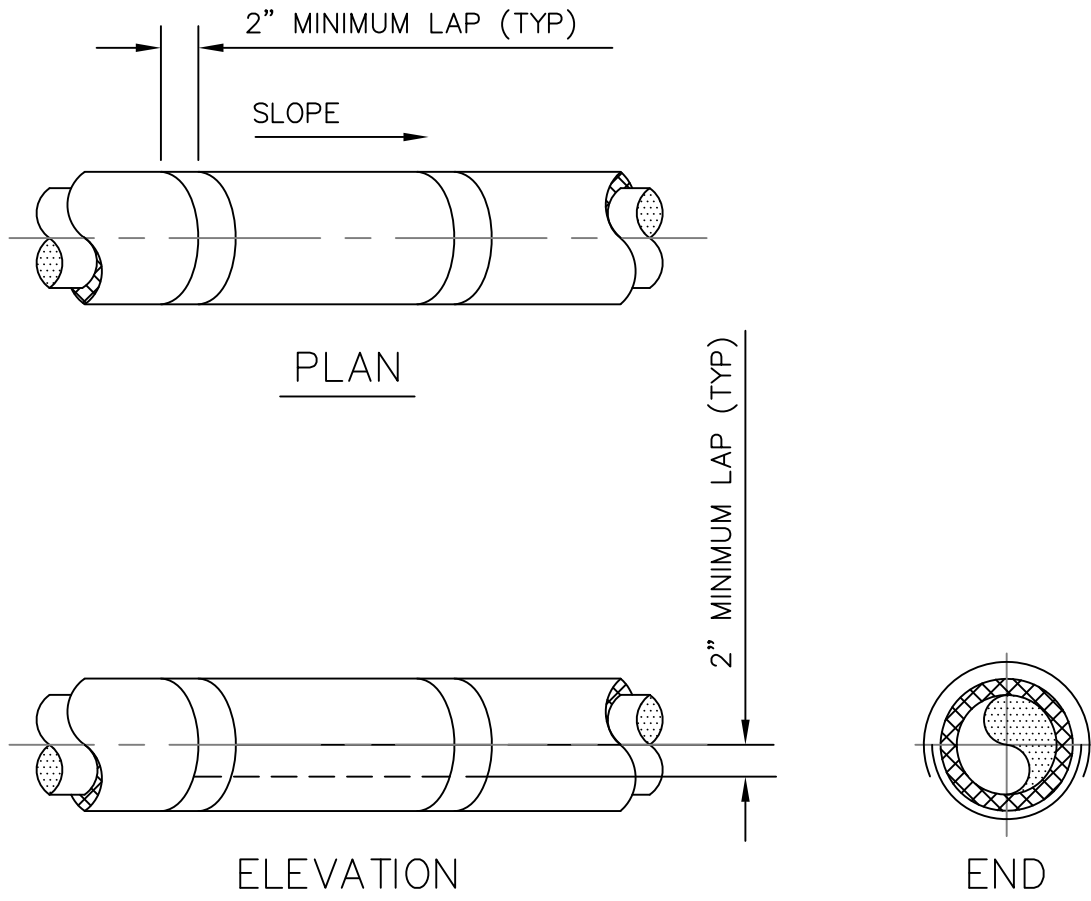

NOTES:

1. HYDROUS CALCIUM SILICATE PIPE INSULATION: THERMO-12/GOLD MEETING ASTM C 533, TYPE1; RIGID MOLDED PIPE; ASBESTOS-FREE COLOR CODED THROUGHOUT MATERIAL THICKNESS.
2. COMPRESSIVE STRENGTH: MINIMUM OF 100 PSI.
3. TIE WIRE: 16 GAGE (0.045mm) STAINLESS STEEL WITH TWISTED ENDS ON MAXIMUM 12 INCH (300mm) ENTERS.
4. ALUMINUM JACKET: 0.016 INCH (0.045 mm) THICK SHEET, (EMBOSSED) FINISH, WITH LONGITUDINAL SLIP JOINTS AND 2 INCH (50mm) LAPS, DIE SHAPED FITTING COVERS WITH FACTORY APPLIED MOISTURE BARRIER. STAINLESS STEEL BANDS MINIMUM EVERY 12" O.C.

**EXTERIOR ABOVE GROUND
INSULATION INSTALLATION DETAIL**

NTS

MIT Department of
FACILITIES

77 Massachusetts Avenue, Cambridge, MA 02139

M2

ANVIL FIG 439, TYPE 3
(GALVANIZED FOR
EXTERIOR USE ONLY)

ANVIL FIG 439, TYPE 3
PTFE HOLD DOWN SLIDE
BASE (GALVANIZED FOR
EXTERIOR USE ONLY)
BOLT TO STRUCTURAL
FRAME

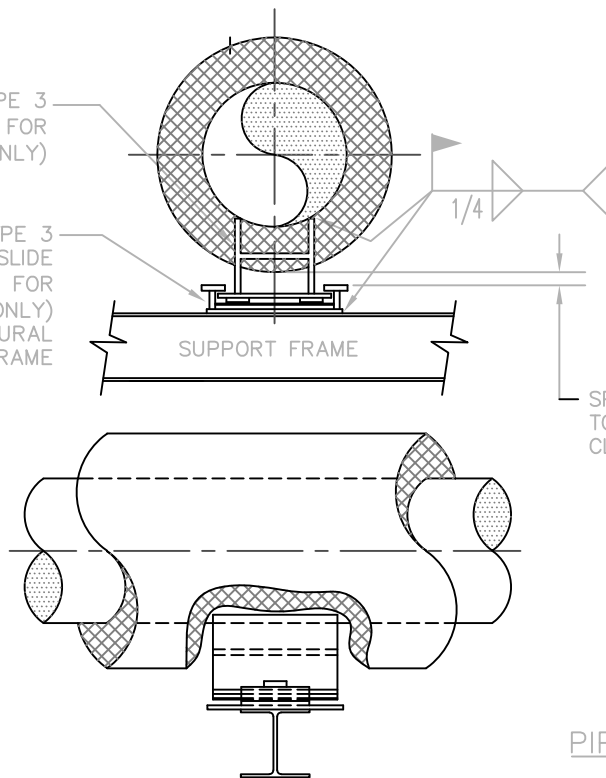

PIPE GLIDE DETAIL
NTS

ANVIL FIG 436,
TYPE 4
(GALVANIZED FOR
EXTERIOR USE
ONLY)

ANVIL FIG 436,
TYPE 2 PTFE SLIDE
BASE (GALVANIZED
FOR EXTERIOR USE
ONLY) BOLT TO
STRUCTURAL FRAME

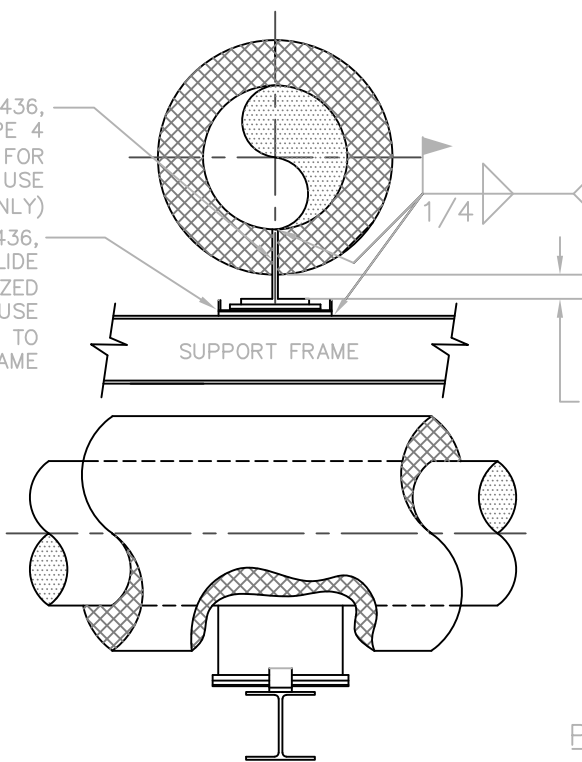

WELD TEE TO PIPE AND
BOLT SLIDE BASE TO
STRUCTURAL FRAME

SPECIFYING ENGINEER
TO INDICATE ADEQUATE
CLEARANCE

PIPE SLIDE DETAIL
NTS

TYPICAL PIPE DETAILS

NTS

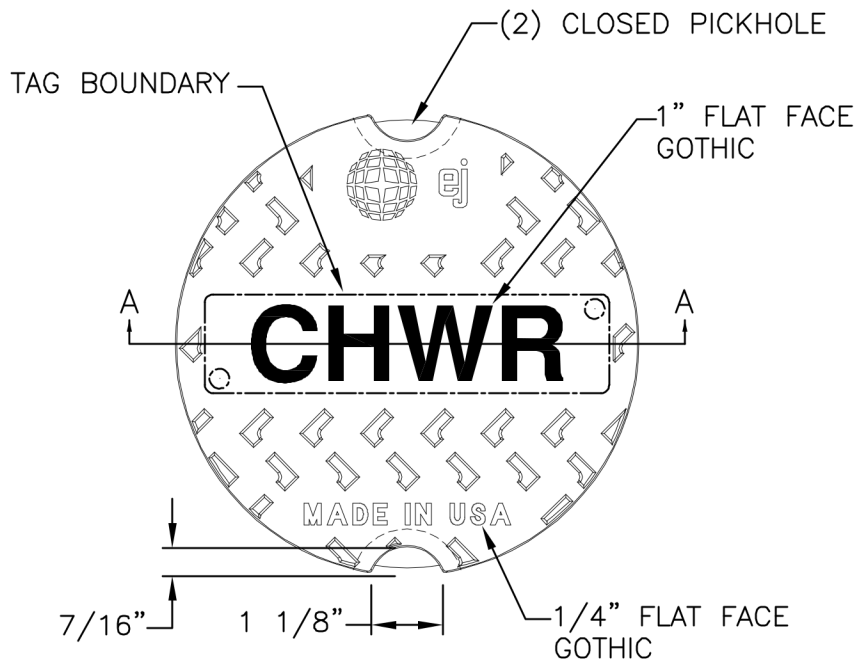

PLAN VIEW

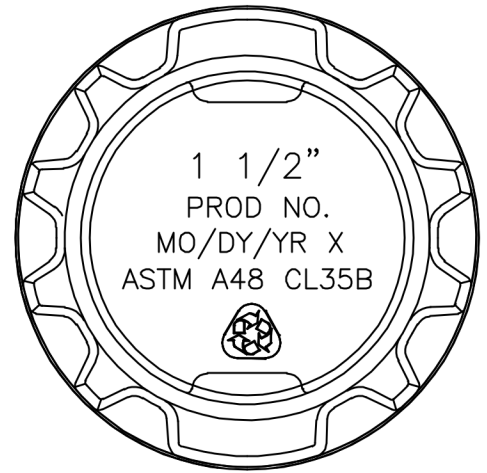

BOTTOM VIEW

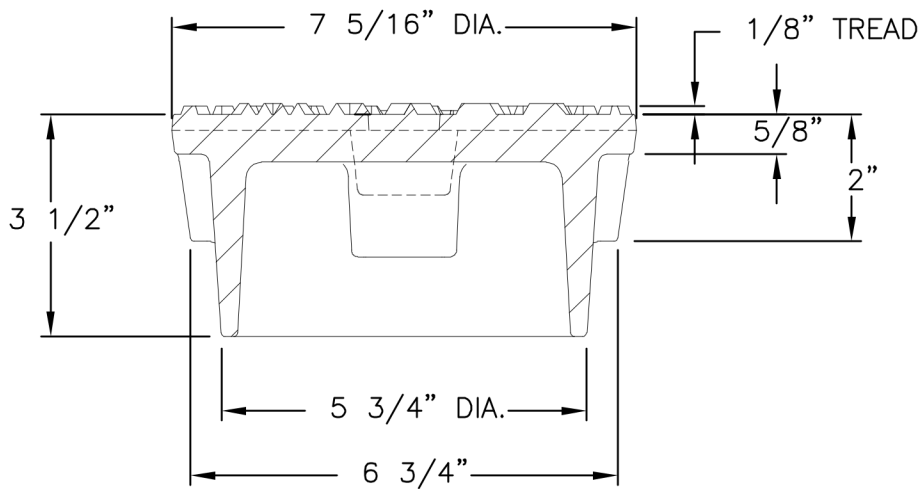

COVER SECTION

VALVE BOX COVER - EJ 06800184

NTS

MIT Department of
FACILITIES
77 Massachusetts Avenue, Cambridge, MA 02139

M4

HEAVY DUTY CLEVIS HANGER
 (FOR 1/2" UP TO & INCL. 3" PIPE)
 ANVIL FIG 300

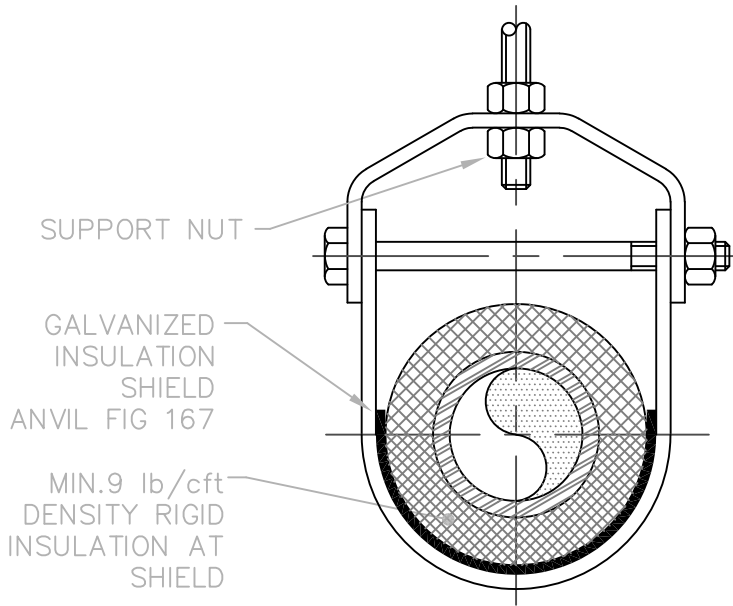

ADJUSTABLE HANGER WITH ROLLER
 (FOR 4" TO 6" PIPE)
 ANVIL FIG 181

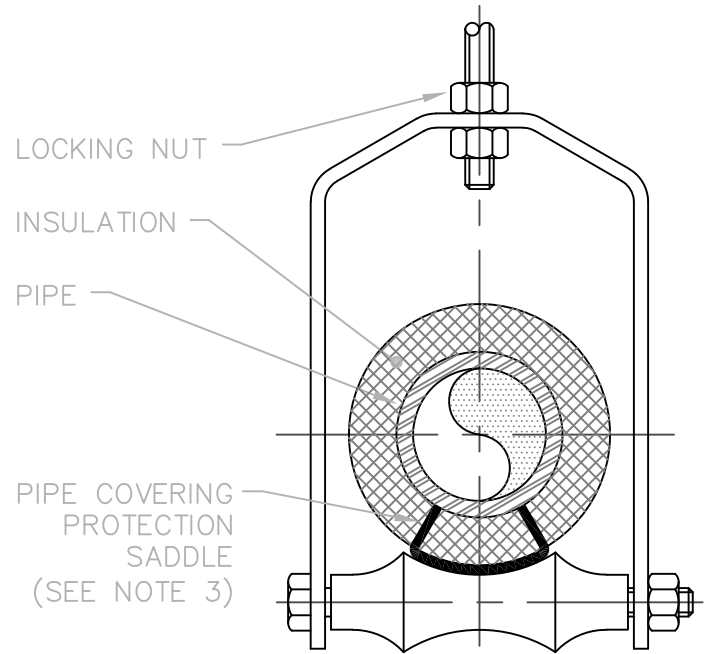

NOTES:

1. SPECIFYING ENGINEER TO PROVIDE SPECIFICATIONS FOR HANGER SIZES.
2. PIPE 8" AND LARGER SHALL HAVE ROLLER SUPPORTED WITH DUAL RODS.
3. ANVIL FIG 160 – 166A. (BASE ON INSULATION THICKNESS.)

PIPE HANGER SUPPORT

NTS

MIT Department of
FACILITIES

77 Massachusetts Avenue, Cambridge, MA 02139

M5

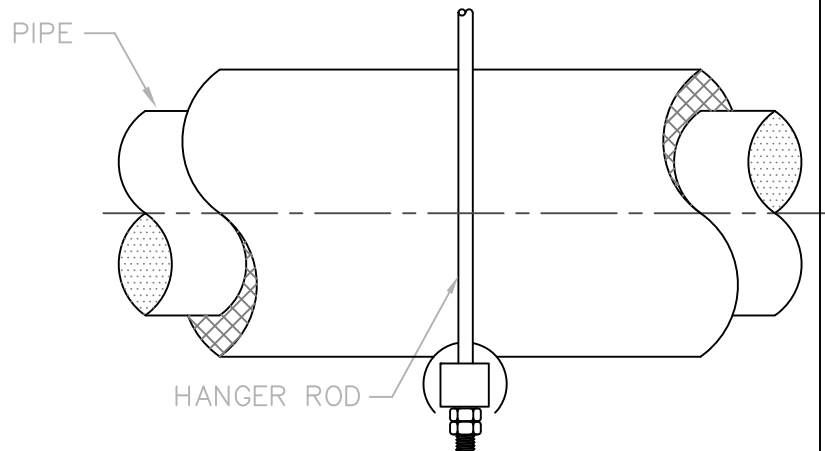
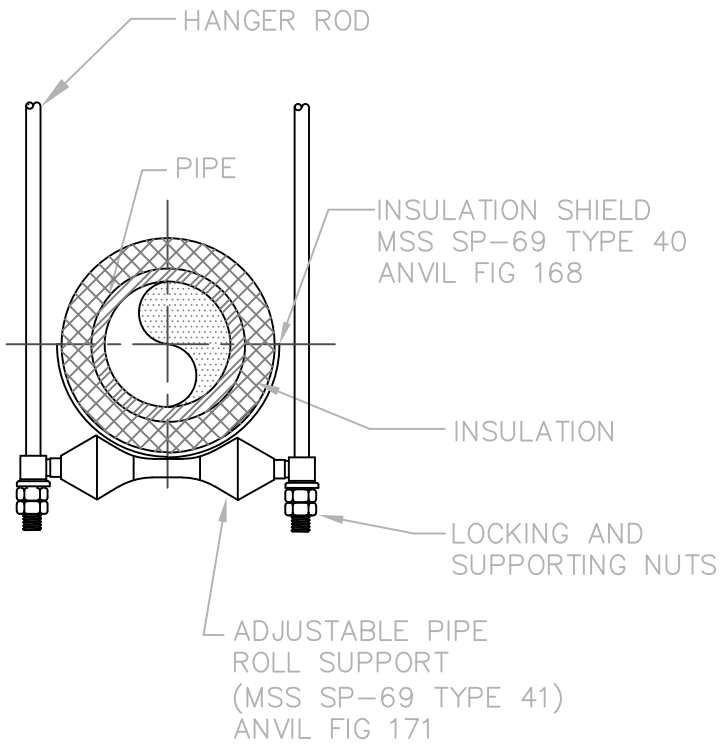

NOTES:

1. SPECIFYING ENGINEER TO PROVIDE DETAIL FOR INSULATION SYSTEM AT POINT OF SUPPORT.
2. ROLLER ASSEMBLY MAY BE FLOOR SUPPORTED USING ADJUSTABLE PIPE ROLL STAND (MSS SP-69 TYPE 46) OR APPROVED EQUAL. ANVIL FIG 177.

SINGLE PIPE SUPPORT

NTS

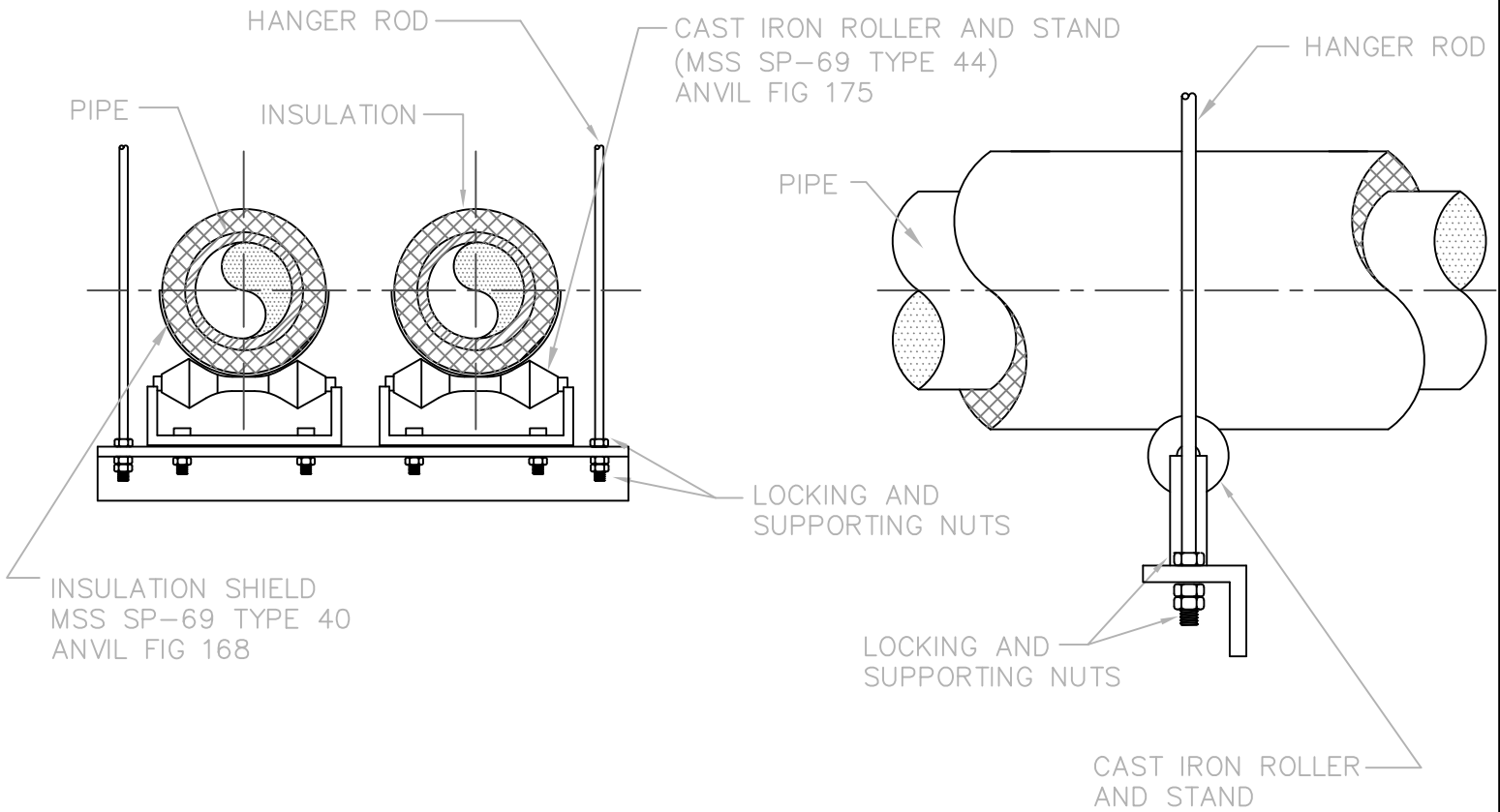

NOTES:

1. SPECIFYING ENGINEER TO PROVIDE DETAIL FOR INSULATION SYSTEM AT POINT OF SUPPORT.
2. ROLLER ASSEMBLY MAY BE FLOOR SUPPORTED USING ADJUSTABLE PIPE. ROLL STAND (MSS SP-69 TYPE 46) OR APPROVED EQUAL.

MULTIPLE PIPE SUPPORT

NTS

MIT Department of
FACILITIES

77 Massachusetts Avenue, Cambridge, MA 02139

M7

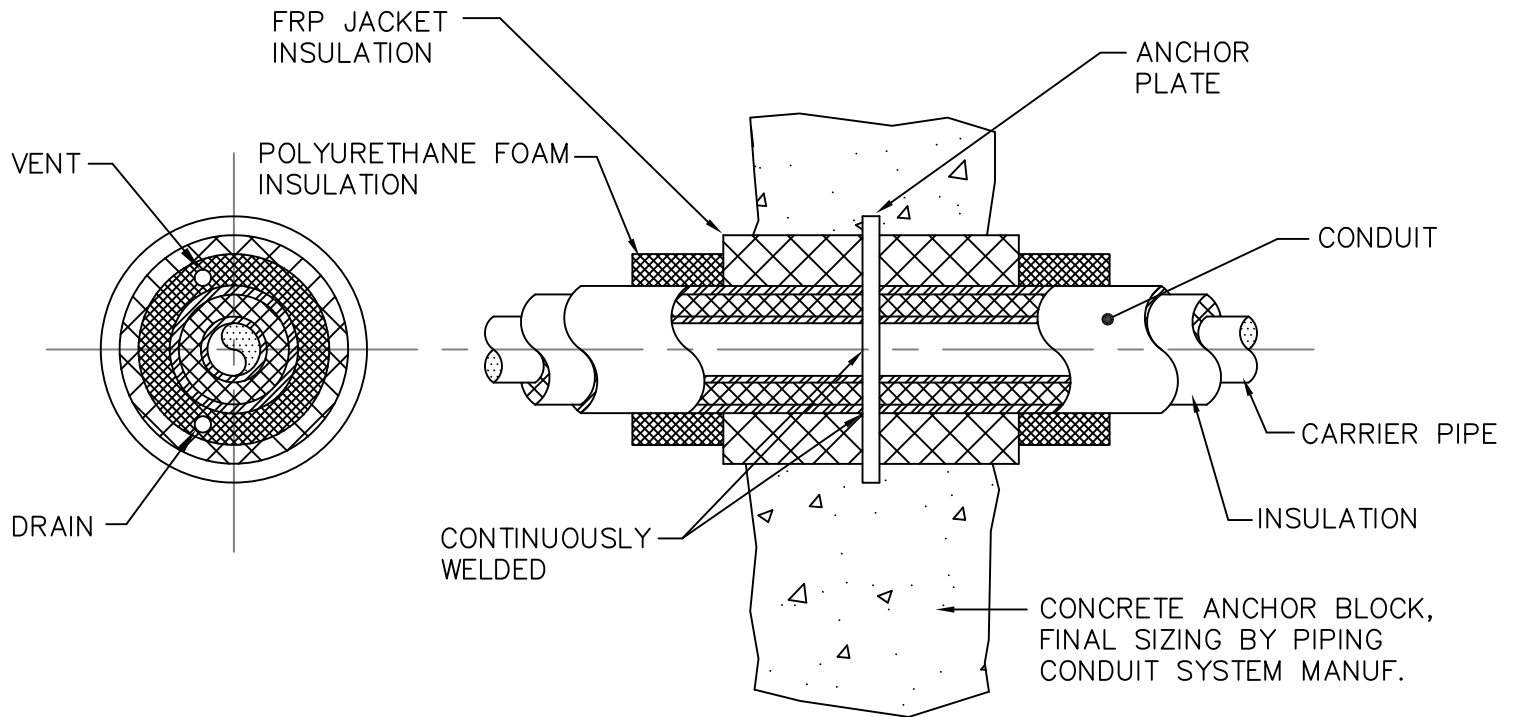

NOTES:

1. ANCHOR PLATE THICKNESS SHALL BE 1/2" UP TO 22" CONDUIT SIZE AND 3/4" FOR CONDUITS LARGER THAN 24".
2. PROVIDE REBAR IN ANCHOR BLOCK, ATTACHED TO ANCHOR PLATE, AS NECESSARY.

STANDARD ANCHOR ASSEMBLY

NTS

MIT Department of
FACILITIES

77 Massachusetts Avenue, Cambridge, MA 02139

M8

RESERVED FOR FUTURE USE

NTS

MIT Department of
FACILITIES

77 Massachusetts Avenue, Cambridge, MA 02139

M9

RESERVED FOR FUTURE USE

NTS

MIT Department of
FACILITIES
77 Massachusetts Avenue, Cambridge, MA 02139

M10

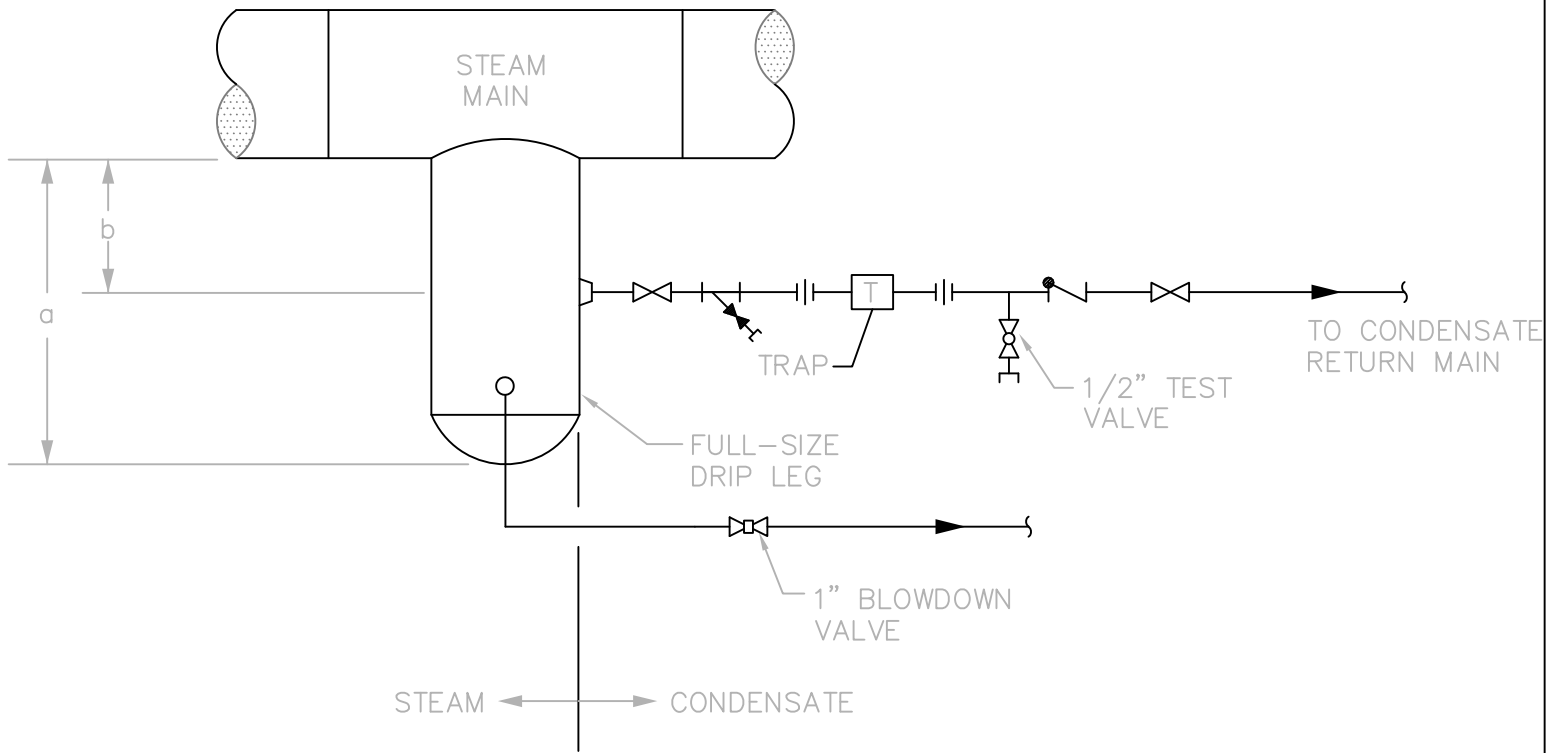

NOTES:

1. SPECIFYING ENGINEER TO INDICATE DIMENSIONS a & b.
2. TRAPS ARE NOT TO BE INSULATED.

**DIRT LEG AND STEAM TRAP DETAIL
LOW & MEDIUM PRESSURE - BLDG RETURN**

NTS

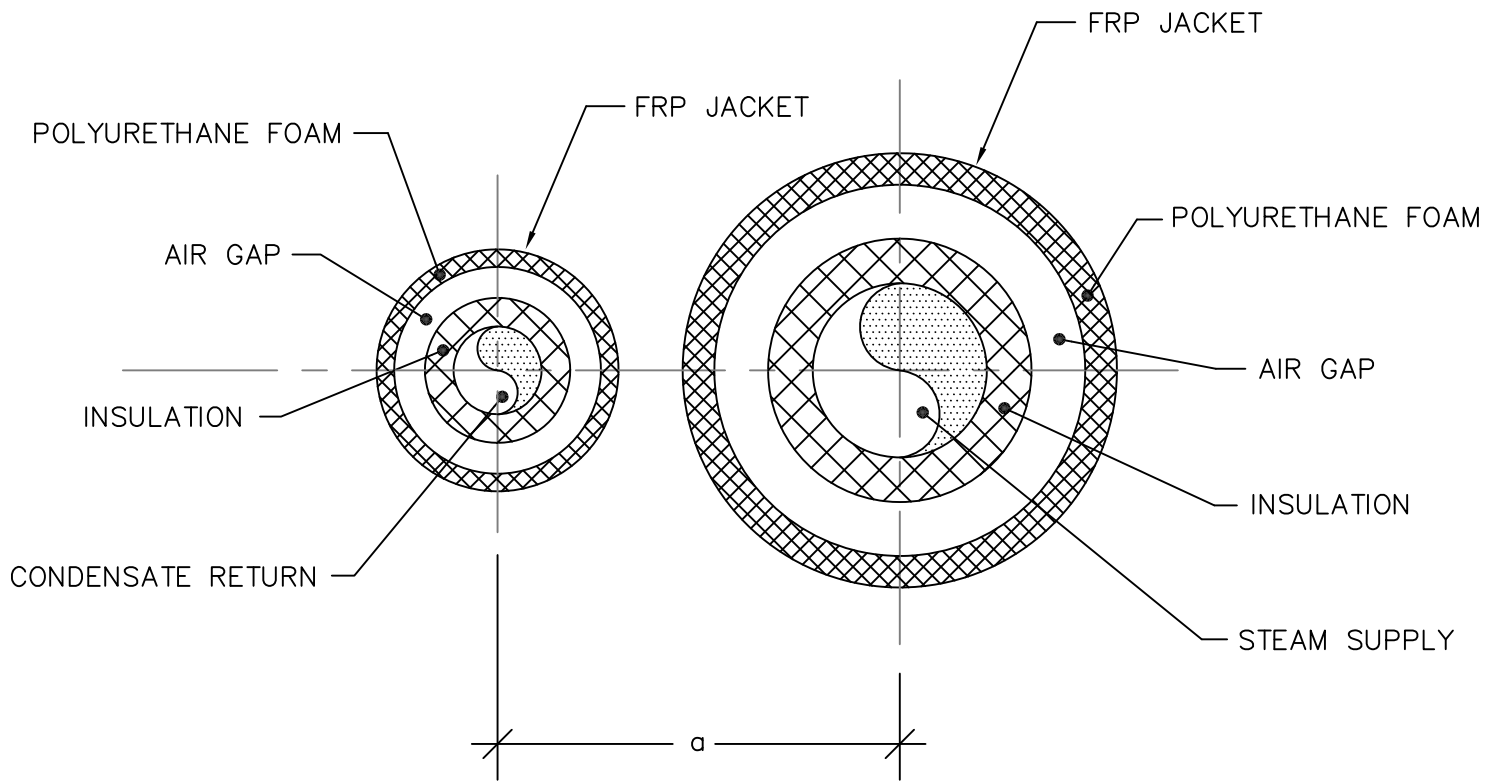

NOTES:

1. SPECIFYING ENGINEER TO INDICATE ADEQUATE DISTANCE a .

**CROSS SECTION OF ENGINEERED PIPE
STEAM SUPPLY AND CONDENSATE RETURN**

NTS

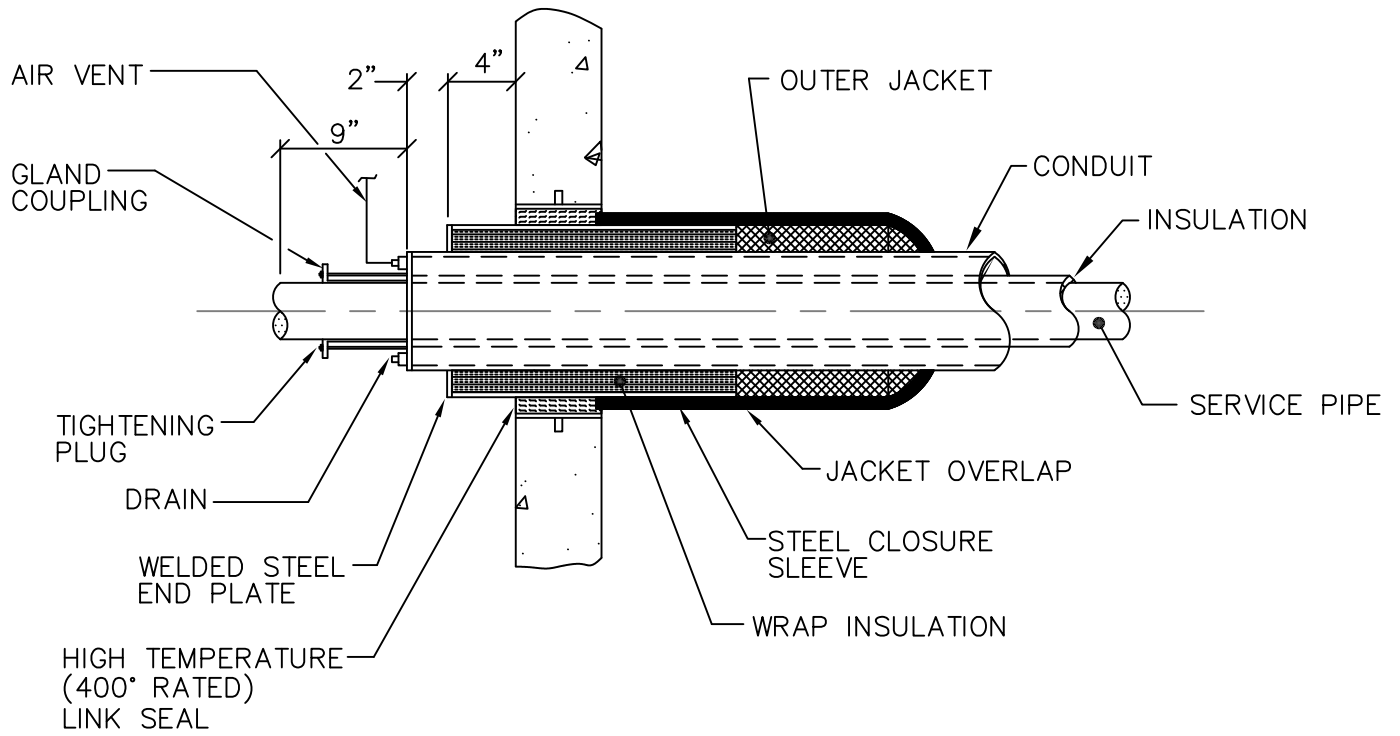

NOTES:

1. COAT ALL METALLIC PORTIONS OF THE END SEAL & STEEL CLOSURE SLEEVE WITH PAINT PROTECTIVE COATING.

GLAND SEAL ASSEMBLY

NTS

MIT Department of
FACILITIES

77 Massachusetts Avenue, Cambridge, MA 02139

M13

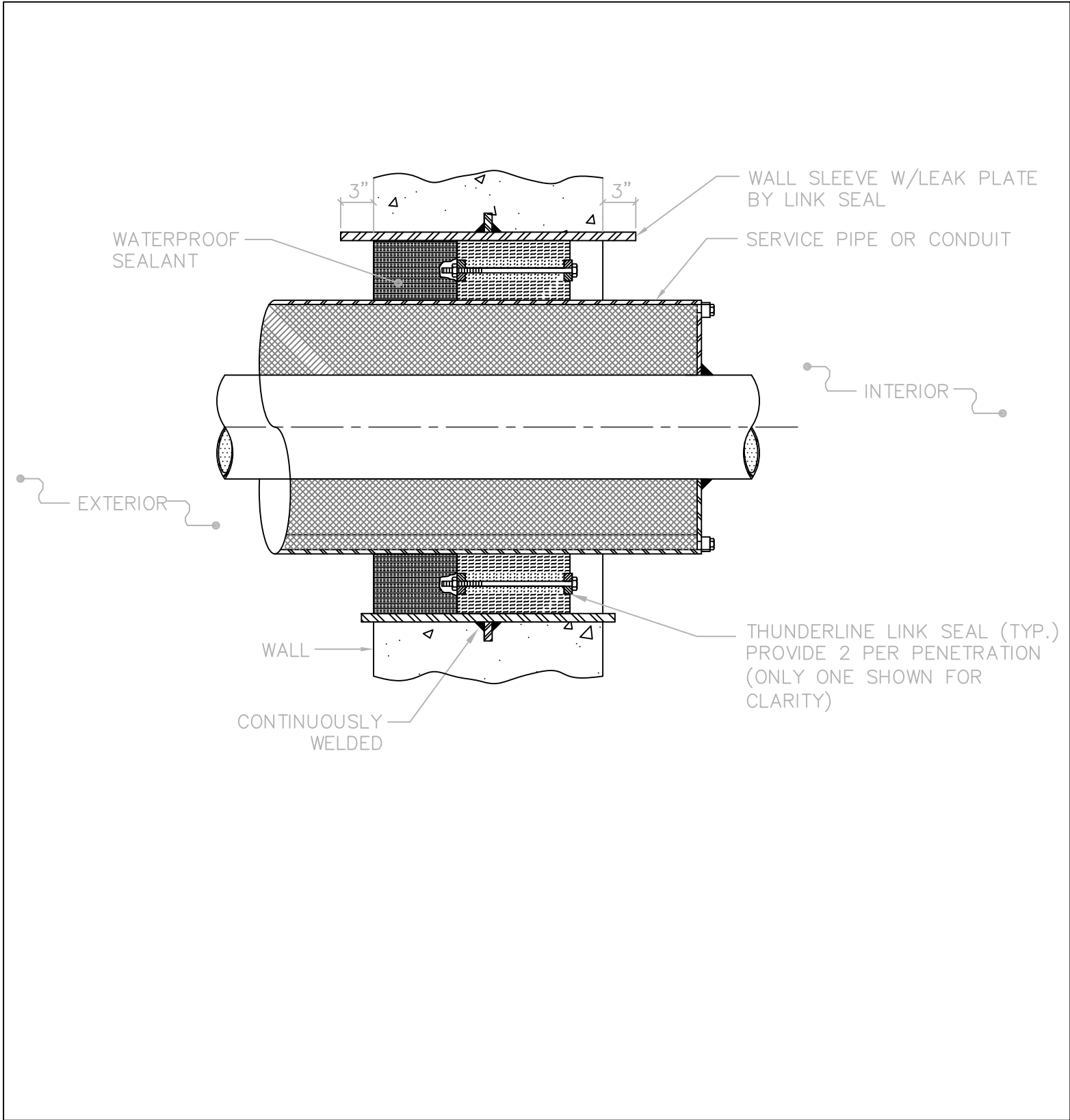

<p>WALL PENETRATION FOR UNDERGROUND MECHANICAL SERVICES</p>	<p>NTS</p>
--	-------------------

SPECIFYING ENGINEER TO
INDICATE SUFFICIENT DISTANCE
FROM ANY WALL OR STRUCTURE

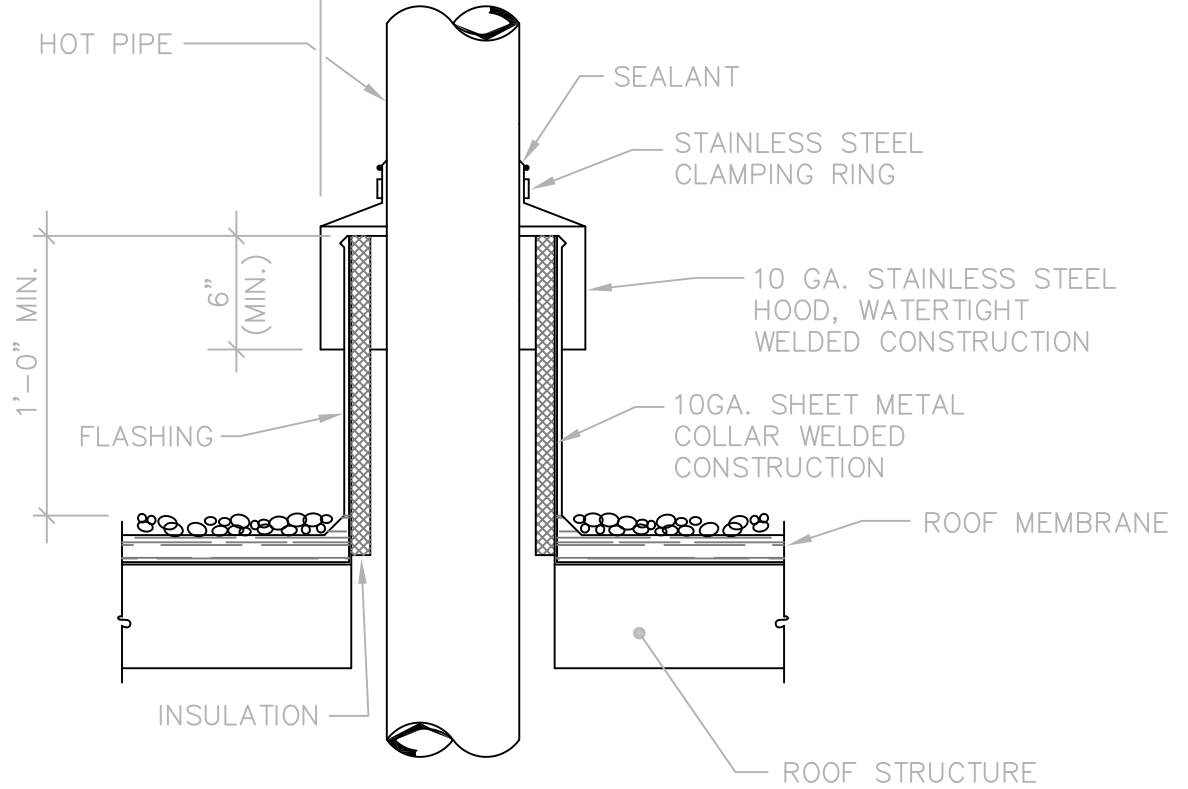

HOT PIPE PENETRATION DETAIL

NTS

RESERVED FOR FUTURE USE

NTS

MIT Department of
FACILITIES
77 Massachusetts Avenue, Cambridge, MA 02139

M16

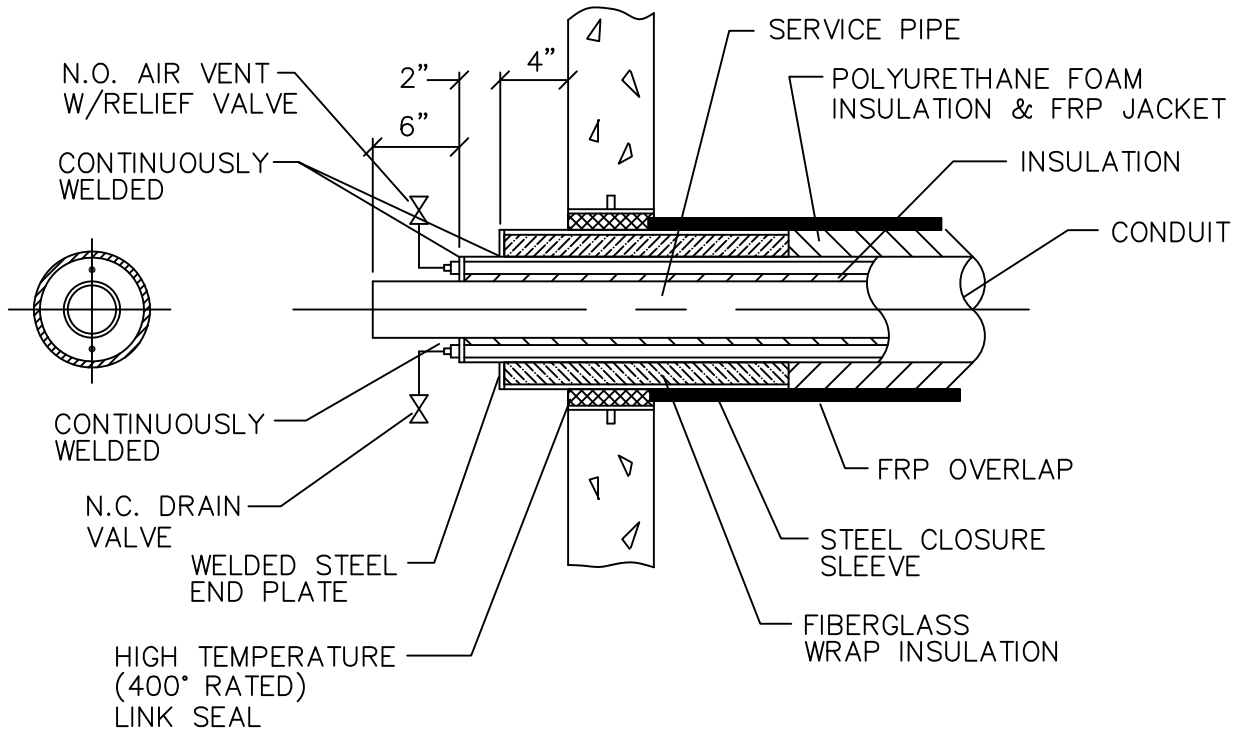

NOTES:

1. COAT ALL METALLIC PORTIONS OF THE END SEAL & STEEL CLOSURE SLEEVE WITH PAINT PROTECTIVE COATING.

CONDENSATE END SEAL ASSEMBLY

NTS

NOTE: PROVIDE A 6" SECTION OF FLEXIBLE BRAIDED METAL HOSE, SUITABLE FOR THE SYSTEM OPERATING PRESSURE AND TEMPERATURE, DIRECTLY BEFORE THE PIPING CONNECTION AT THE FLASH ARRESTOR.

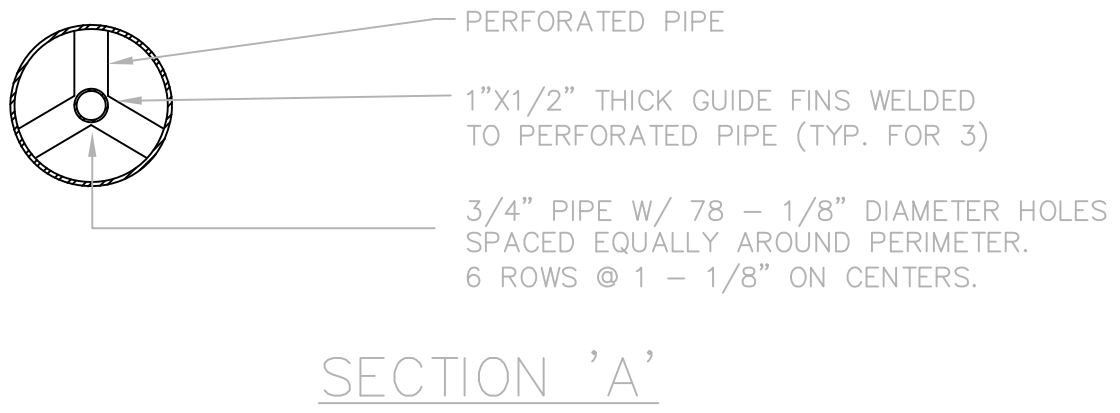
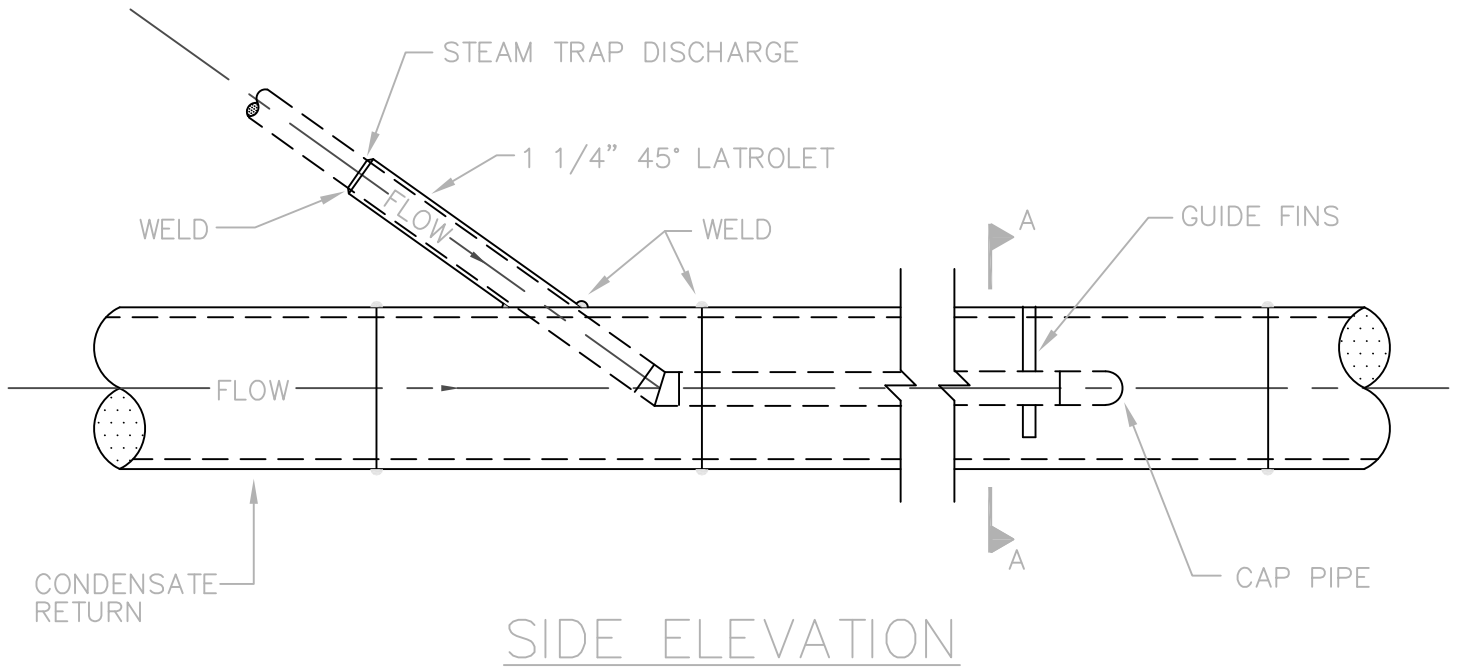

**HIGH PRESSURE CONDENSATE
RETURN SPARGER**

NTS

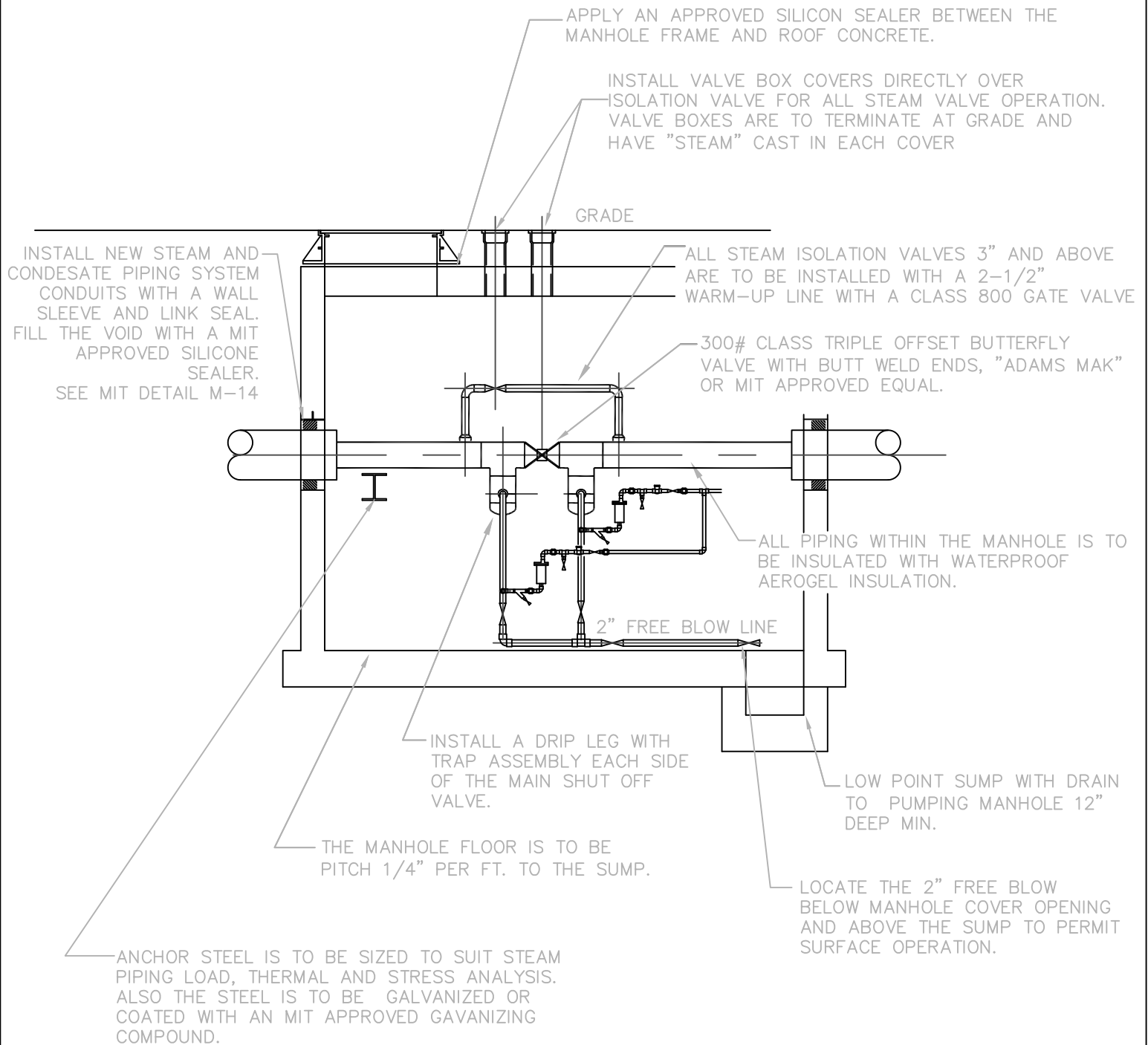

**TYPICAL STEAM MANHOLE LAYOUT
ELEVATION**

NTS

RESERVED FOR FUTURE USE

NTS

MIT Department of
FACILITIES

77 Massachusetts Avenue, Cambridge, MA 02139

MH2

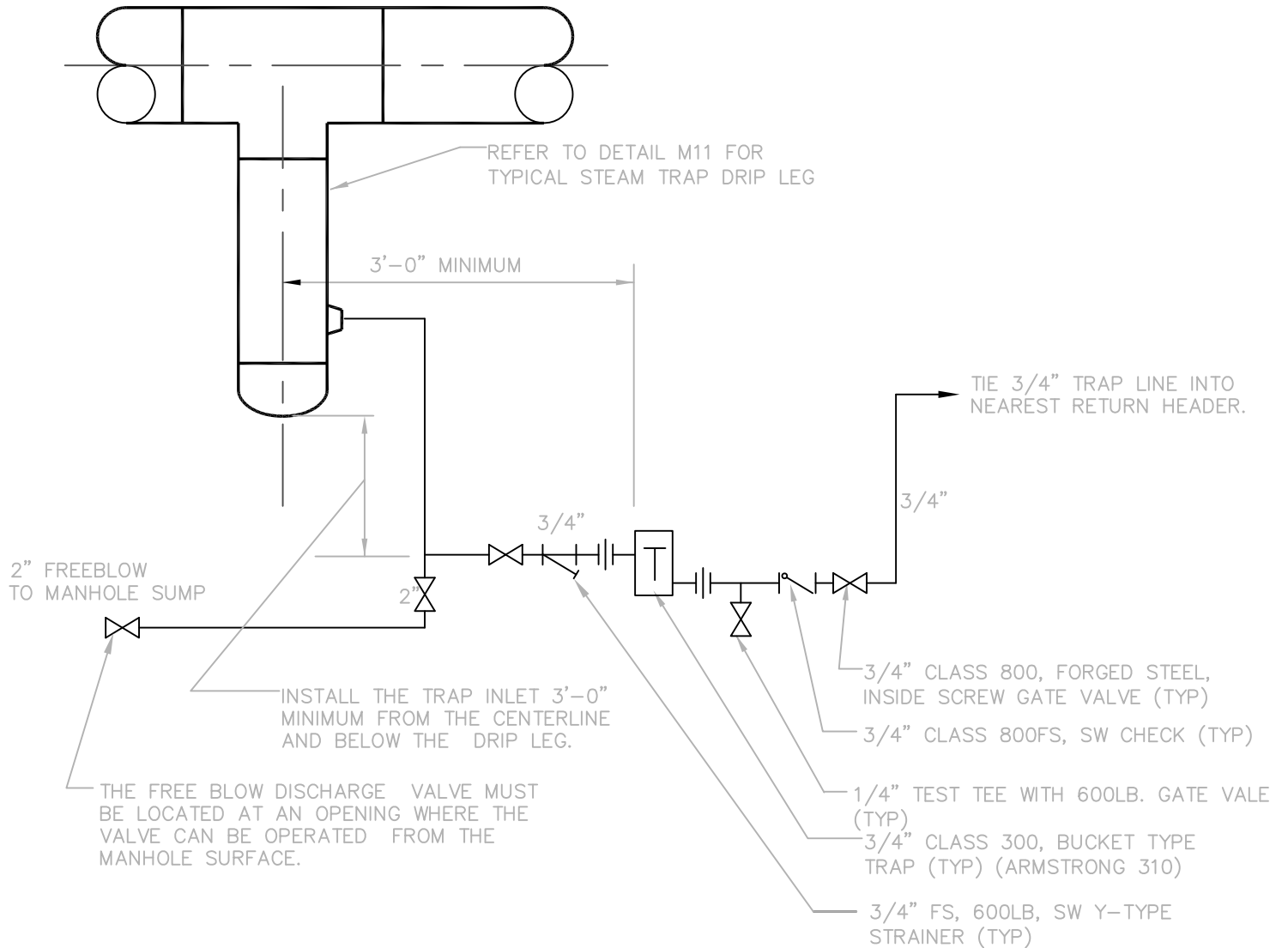

NOTES:

1. TRAPS ARE NOT TO BE INSULATED

**TYPICAL TRAP ASSEMBLY DETAIL
HIGH PRESSURE STEAMMANHOLES**

NTS

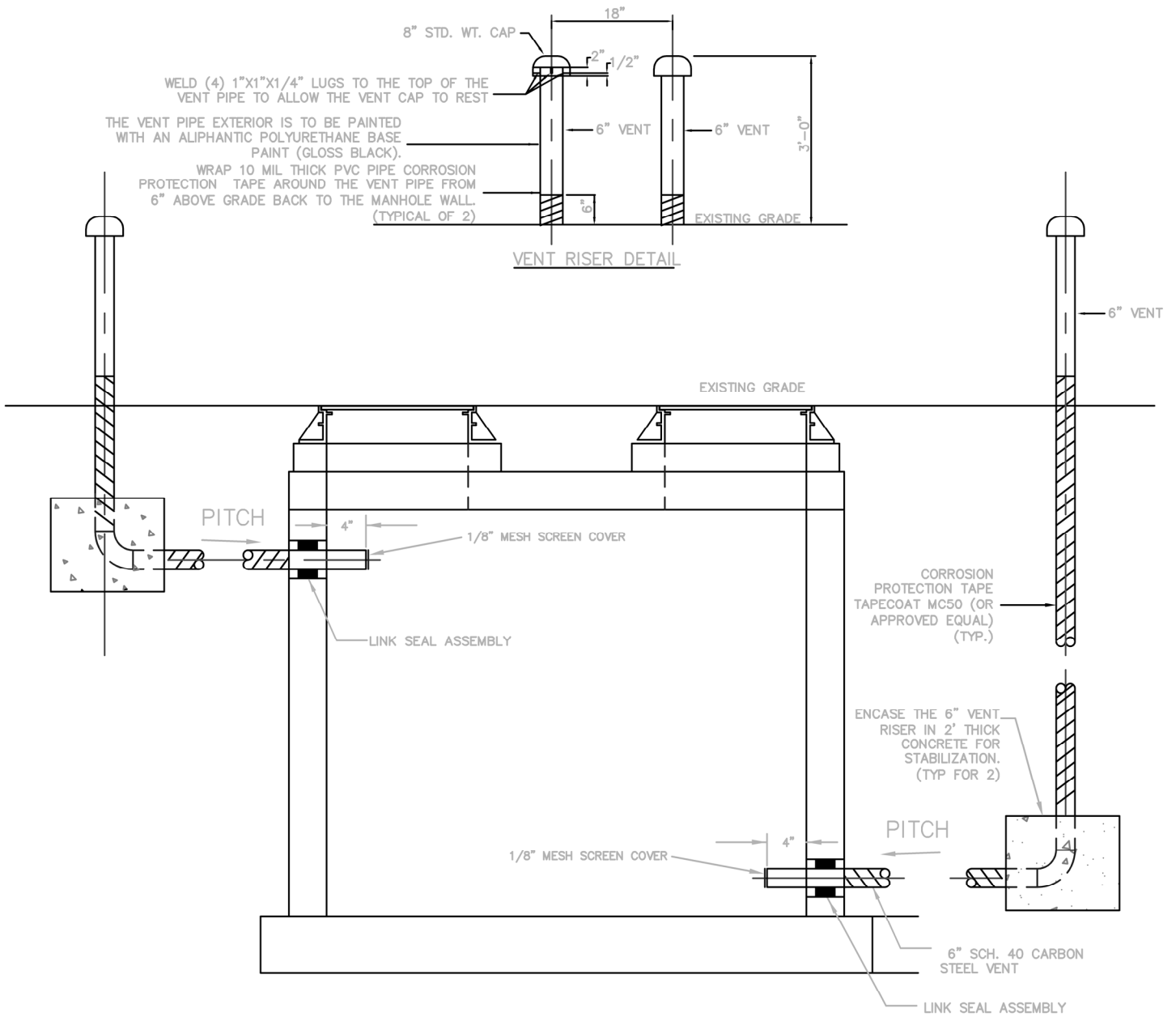

NOTE:

1. VENTS ARE TO BE LOCATED IF POSSIBLE NEAR A BUILDING WALL AND AWAY FROM OPEN WINDOWS OR INTAKE VENTS.

TYPICAL MANHOLE VENT DETAIL

NTS

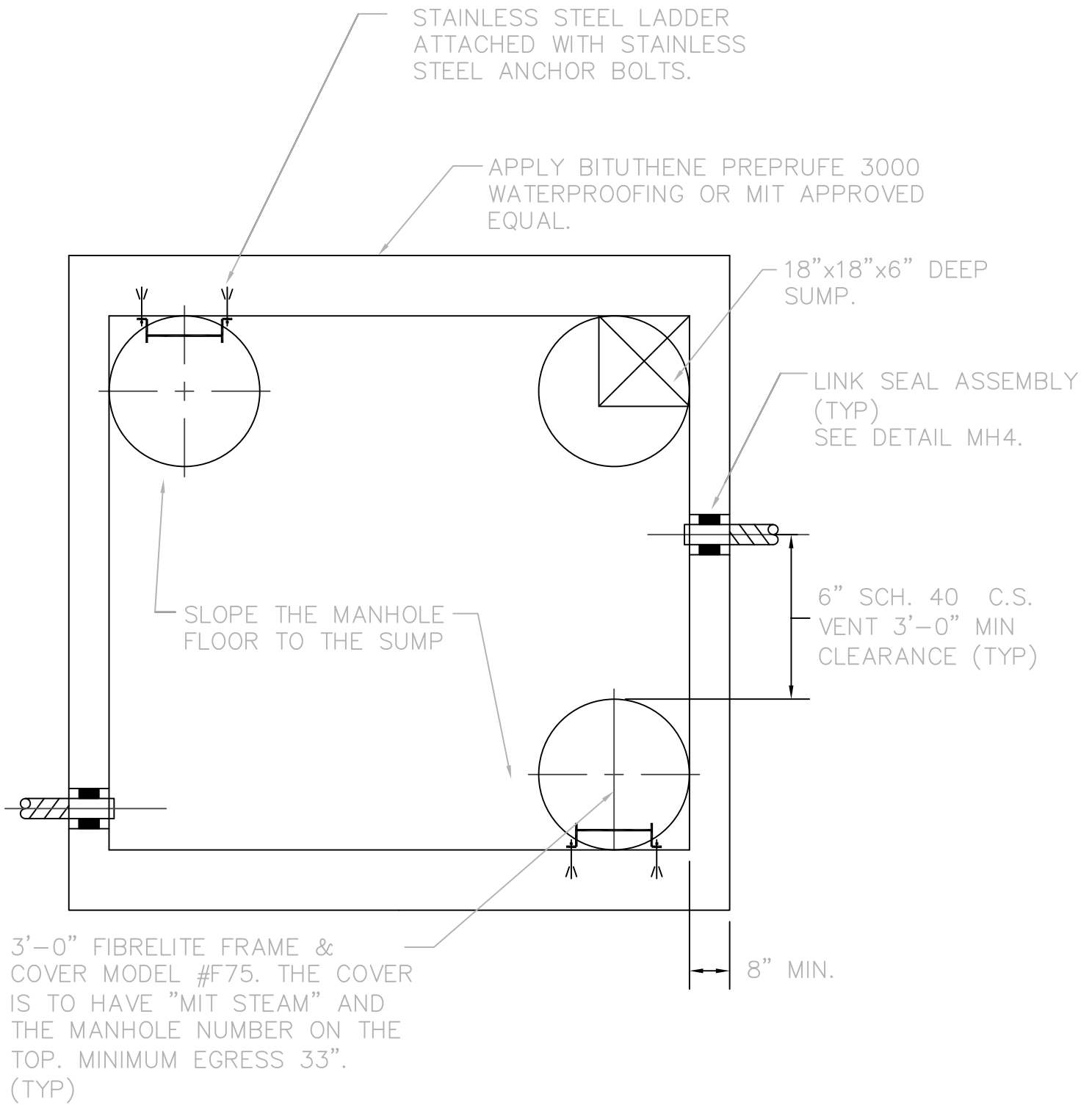

**TYPICAL MANHOLE LAYOUT - PLAN
STEAM**

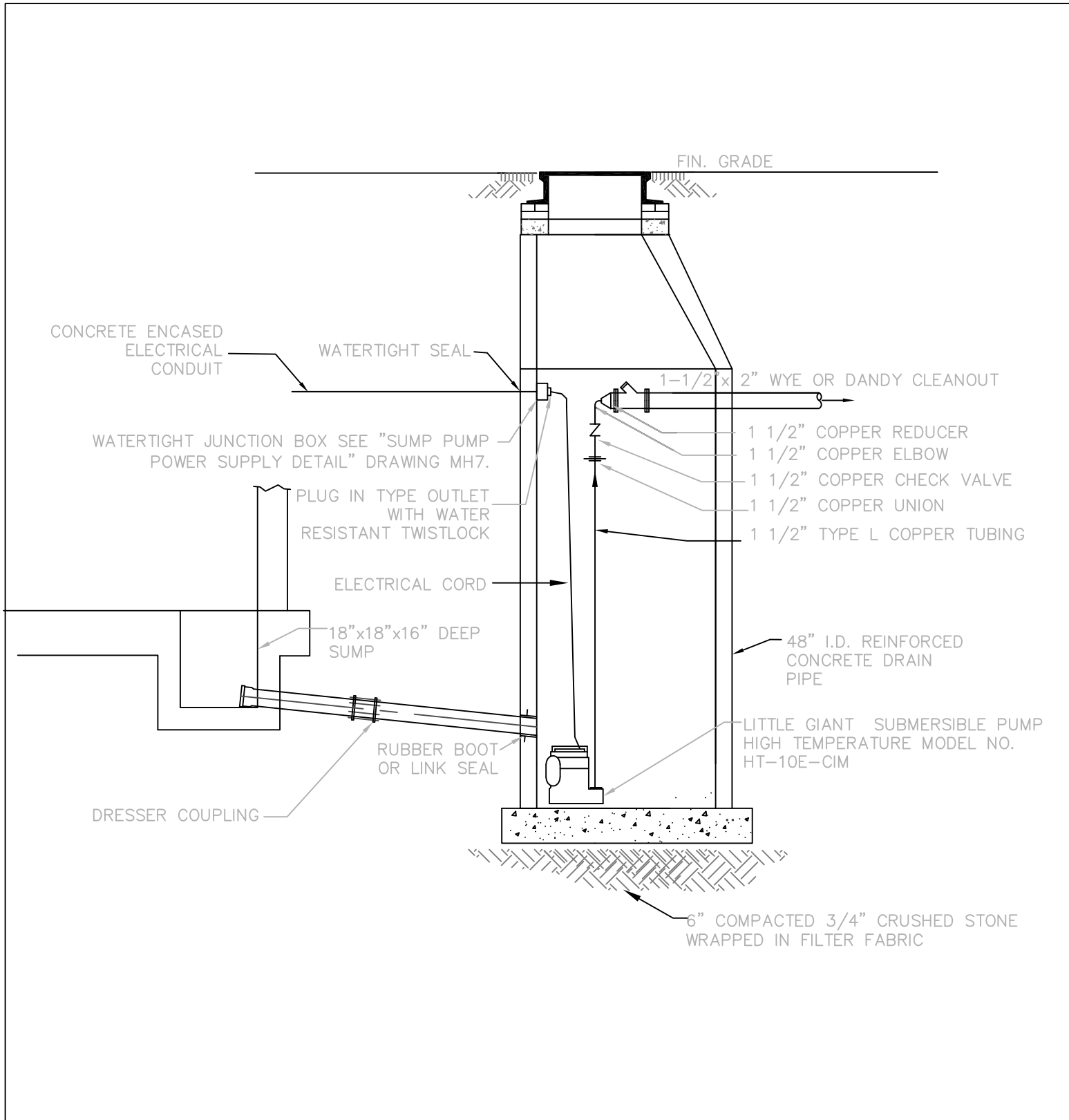

TYPICAL PUMPING MANHOLE DETAIL

NTS